

Vivitar

Service Manual

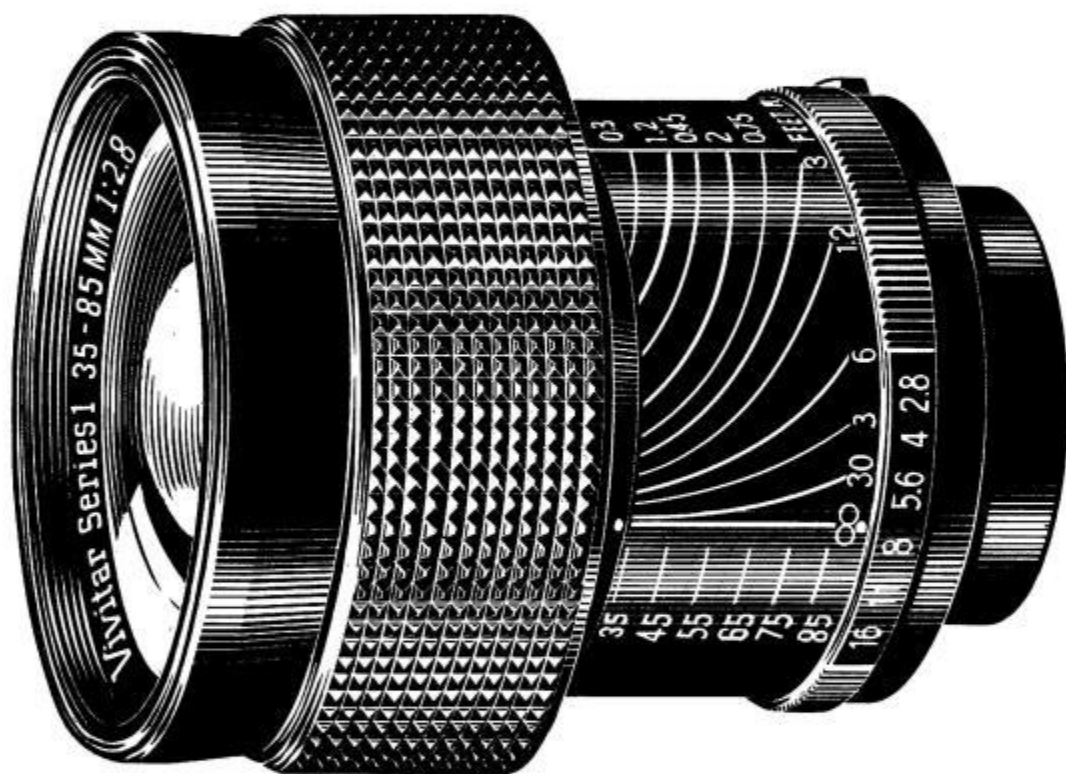

Series 1 Lens 35-85mm f/2.8 Varifocal

Publication No. 3746050A / June 1979

This publication consists of the following pages:

<u>Page</u>	<u>Revision</u>	<u>Date</u>
Cover/Page A	A	6/79
i – iv	A	6/79
1 – 75	A	6/79

HOW TO USE THIS PUBLICATION

HOW TO FIND PART ORDER NUMBERS

Parts are illustrated on exploded view drawings where each part is identified by a reference number or designator. These reference numbers appear in sequence in the parts lists where they are cross-referenced to the part numbers and descriptions.

When a part is not available separately it will be so indicated by a footnote and can be obtained by ordering the assembly containing it. The part number of that assembly may be shown immediately to the right on the same line in an "Included in Assembly" column or at the end of the parts list(s).

In parts lists for lens items, quantities of each item are listed as used in the different lens mounts. The mounts are referred to as:

U	=	Vivitar-Universal Thread Mount	K	=	Konica Autoreflex Series Mounts
N/F	=	Nikon F Mounts	O	=	Olympus OM Series Mount
M	=	Minolta Mounts	P	=	Pentax K Mounts
C	=	Canon Mounts	N/AI	=	Nikon AI Mounts

Note that many parts are common to more than one mount. This commonality is shown in the complete parts list at the end of the manual so that the service centers desiring to stock replacement parts can order economically.

CAUTION

This publication is intended for use by persons having skills and equipment needed to service the subject product(s) safely and correctly. Users are cautioned that special tools and/or test equipment may be required for proper disassembly, reassembly, alignment or adjustment or damage to the product may result.

Notice: Information contained herein is subject to change without notice.

HOW TO ORDER PARTS

Please furnish the model number and serial number of the product for which parts are being ordered. For each part requested, please supply part order number, description, and required quantity. Mail or phone parts orders to:

Vivitar Central Parts Service
2700 Pennsylvania Avenue
Santa Monica, California 90406

Telephone: (213) 829-3672
or (213) 870-0181

VIVITAR SERIES 1 LENS – 35-85mm f/2.8 VARIFOCAL

TABLE OF CONTENTS

	PAGE
IDENTIFICATION AND MOUNT CONFIGURATIONS	1
GENERAL INFORMATION	2
DESIGN FEATURES	2
OPTICAL SPECIFICATIONS	2
MECHANICAL SPECIFICATIONS	2
USE OF PARTS LIST	2
REPAIR NOTES	3
HINTS AND PRECAUTIONS	3
LUBRICATION SCHEDULE	3
1.0 DISASSEMBLY OF OPTICAL GROUPS FROM LENS	5
1.1 FIRST LENS GROUP	5
1.2 SECOND LENS GROUP	6
1.3 THIRD LENS GROUP	6
1.4 FOURTH LENS GROUP	6
1.5 FIFTH LENS GROUP	6
2.0 REMOVAL OF LENS MOUNTS FROM LENS	7
2.1 VIVITAR-UNIVERSAL SERIES THREAD MOUNT	7
2.2 NIKON F/EL SERIES MOUNT	9
2.3 MINOLTA SR/XK SERIES MOUNT	10
2.4 CANON FL/FD SERIES MOUNT	10
2.5 KONICA AUTOREFLEX SERIES MOUNT	11
2.6 OLYMPUS-OM SERIES MOUNT	13
3.0 PRIME LENS ASSEMBLY	14
3.1 REMOVAL OF PRIME LENS	15
3.2 REPLACEMENT	15
3.3 DISASSEMBLY	15
3.4 REASSEMBLY	16
3.5 INSTALLING A NEW DIAPHRAGM HOUSING	17
4.0 DISASSEMBLY OF MAIN LENS	18
4.1 CONTROL HOUSING	18
4.2 HELICOID ASSEMBLY	19
4.3 INNER HELICOID ASSEMBLY	19
4.4 CLEANING OF HELICOIDS AND SLIDE HOUSINGS	21
4.5 LUBRICATION	22
5.0 REASSEMBLY OF MAIN LENS	23
5.1 INNER HELICOID	24
5.2 MIDDLE AND OUTER HELICOID TO INNER HELICOID	25
5.3 BRIDGE RING	26

TABLE OF CONTENTS (CONTINUED)

	PAGE
5.4 CONTROL HOUSING	27
5.4.1 INDEX RING	27
5.4.2 CAM RING	27
5.4.3 CONTROL RING	28
5.4.4 INNER FOCUSING RING	28
6.0 CENTERING OF OPTICAL COMPONENTS	29
6.1 ADJUSTING THE EYEPIECE	30
6.2 ADJUSTMENT OF COLLIMATOR	30
6.3 CENTERING PROCEDURE (GENERAL)	31
6.4 CENTERING FIRST LENS GROUP	31
6.5 CENTERING OF SECOND LENS	32
6.6 CENTERING OF THIRD LENS GROUP HOUSING	32
6.7 CENTERING OF FOURTH LENS IN DIAPHRAGM HOUSING	33
6.8 CENTERING OF SECOND LENS GROUP IN LENS BARREL	34
7.0 FOCUS ADJUSTMENT	36
7.1 TEST EQUIPMENT	36
7.2 DEFINITIONS	36
7.3 FOCUS SPACERS	37
7.4 GENERAL FOCUSING PROCEDURE	37
7.4.1 35mm INFINITY FOCUS	37
7.4.2 85mm INFINITY FOCUS	38
7.4.3 FOCUS ADJUSTMENT CHECK	38
8.0 CONTROL RING DRAG ADJUSTMENT	38
9.0 SPECIAL TOOLS	39
9.1 VIVITAR TOOL NO. 3650530 – CANON MOUNT	39
9.2 VIVITAR TOOL NO. 3650531 – CANON MOUNT	40
9.3 VIVITAR TOOL NO. 3650532 – OLYMPUS MOUNT	43
10.0 REAR MOUNT ASSEMBLIES	44
10.1 UNIVERSAL SERIES MOUNT	44
10.2 NIKON F/EL SERIES MOUNT	44
10.3 MINOLTA SR/XK SERIES MOUNT	45
10.4 CANON FL/FD SERIES MOUNT	45
10.5 KONICA AUTOREFLEX SERIES MOUNT	46
10.6 OLYMPUS–OM SERIES MOUNT	46
11.0 VIVITAR SERVICE TOOL FOR 35-85mm VARIFOCAL LENS	47
12.0 ILLUSTRATED PARTS LIST	51

LIST OF ILLUSTRATIONS

NOTE

Illustrations in the maintenance sections have no titles and are not listed.

<u>Figure</u>	<u>Title</u>	<u>Page</u>
12-1	Parts Common To All Mount Configurations	52
12-1A	Diaphragm Housing Assemblies and Mount Assemblies	55
12-2	Diaphragm Housing Assembly, All Mounts	56
12-3	Universal Mount Assembly, Complete	56
12-4	Nikon F / Nikkormat Assembly, Complete	58
12-5	Nikon AI Mount Assembly, Complete	59
12-6	Minolta MD, SRT, SR Mount Assembly, Complete	60
12-7	Canon FL, FD Mount Assembly, Complete	62
12-8	Konica Autoreflex Assembly, Complete	64
12-9	Olympus OM Mount Assembly, Complete	66
12-10	Pentax K Mount Assembly, Complete	68

**SERIES 1 LENS
35-85mm f/2.8 VARIFOCAL**

IDENTIFICATION AND MOUNT CONFIGURATIONS

This document is the Service Manual with Illustrated Parts List for the Vivitar Series 1, 35-85mm f/2.8 Varifocal Lens. Sections 1 through 11 contain detailed instructions for disassembly, reassembly, lubrication, and adjustment of the lens in its various mount configurations. Section 12 is the Illustrated Parts List with exploded views showing the relationship of all parts to each other. Parts lists on facing pages are indexed to the illustrations and contain part numbers, descriptions, and quantities. A summary Parts List at the end lists all parts in Vivitar part number sequence and shows quantities for each usage of the part in the various mount configurations of the lens.

This lens is currently being supplied in the following mount configurations:

Mount	Vivitar Stock No.	Vivitar Part No.
Universal Thread Series Mount	0311548	3900103
Minolta MD, SRT, SR Series Mount	0311641	3900104
Canon FL, FD Series Mount	0311607	3900105
Nikon/Nikkormat AI, F Series Mounts	0311582	3900106
Konica Autoreflex Series Mount	0311663	3900107
Olympus OM Series Mount	0311696	3900108
Pentax K, M Series Mount	0311700	3900109

A mount configuration to fit Nikon F and Nikkormat (but not Nikon AI) cameras was previously supplied and is illustrated in this manual. Other obsolete mount configurations are not illustrated.

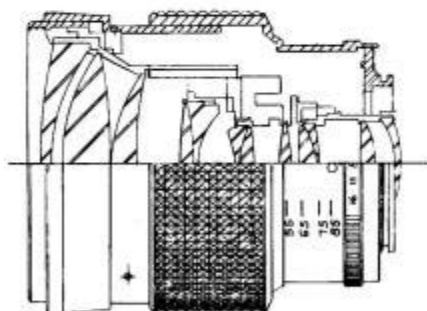

GENERAL INFORMATION

DESIGN FEATURES

1. Both focal length change and focusing are accomplished with a single control.
2. Large maximum aperture.
3. Compact.
4. Excellent image contrast and resolution.

OPTICAL SPECIFICATIONS

Construction	12 elements in 9 groups
Effective focal length	35-85mm
Focal length ratio	2.4.1
Angle of acceptance	28–63 degrees
Minimum focusing distance	Subject to front element 109.2mm Subject to film plane 259mm

MECHANICAL SPECIFICATIONS

Accessory size	72mm
Weight	27 ounces
Length at infinity	91.4mm
Maximum barrel diameter	81.3mm
Aperture range	f2.8-16
Lens hood	Slip-on hood included

REPAIR NOTES

The lens is composed of three main assemblies:

1. MAIN LENS ASSEMBLY (First three lens groups and lens tube and helicoid components)
2. PRIME LENS ASSEMBLY (Fourth and fifth lens groups and diaphragm housing assembly)
3. LENS MOUNT ASSEMBLY (Seven different assemblies)

Most frequent repairs are to the Main Lens Assembly, followed by repairs to the various lens mounts. Repairs to the Prime Lens Assembly are relatively infrequent. Full disassembly and reassembly instructions for each of these assemblies are provided.

In most instances, repairs to the Prime Lens Assembly will not require disassembly beyond removal of lens groups. The Prime Lens Assembly is the most critical part of the lens, because it is precisely aligned to reduce aberrations to the minimum obtainable. Therefore it is recommended that it not be disassembled unless absolutely necessary.

This lens should never be disassembled further than necessary to correct malfunctions.

In the instructions, rotational directions (clockwise - counterclockwise) are as viewed from the FRONT of the lens when referring to the Main Lens Assembly, and from the REAR when referring to the Prime Lens and Lens Mount Assemblies.

HINTS AND PRECAUTIONS

1. Before attempting to remove any screws, apply ketone solvent such as acetone, or methyl-ethyl ketone (MEK) around the screw to soften the thread sealant. If the screw does not readily release, apply more solvent. All rings, screws and pins can be removed with normal pressures. In some cases the tip of a hot soldering iron will soften the thread sealant and allow a screw to be removed.
2. Before finally tightening any screw, apply sealant to the threads.
3. Before removing any retaining ring, flow sufficient solvent into the thread area and allow the sealing agent to soften.
4. Before fully tightening a retaining ring, flow sealant into its threads to lock it in place.
5. On all surfaces which require grease, use only a light film of lubricant. Too much grease has a way of creeping onto parts, such as diaphragm blades which should be dry. (Refer to lubricant table.)
6. Never tighten a setscrew so tight as to split the head or distort the parts around it.
7. Pay particular attention to refocusing the lens. Assure that focus is exactly correct at 35mm and 85mm position and is within tolerance at all intermediate positions.
8. Avoid excessive force, which can lead to expensive (and unnecessary) replacement of parts or assemblies.
9. Cleaning of lens surfaces can usually be accomplished by use of a mixture of 70% ether and 30% alcohol.
10. Before attempting any repair, read the manual thoroughly.

LUBRICATION SCHEDULE

General Area	Lubrication Point	Lubricant
Outer Helicoid (Ref. No. 3)	Helicoid Threads	A-Losimol Losoid 33
Middle Helicoid	Helicoid Threads	Losimol Losoid 72125 B-GE G322L or equivalent
Canon Mount (Ref. Nos. 122 & 124)	Mount Threads and Locking Ring Threads	A-Losimol Losoid 33
First Lens Group Slide Housing	Bearing Surfaces	Losimol Losoid M72125 B-GE G322L or equivalent
Second Lens Group Slide Housing	Bearing Surfaces	Losimol Losoid 72125 B-GE G322L or equivalent*
Third Lens Group Housing	Bearing Surfaces	Losimol Losoid 72125 B-GE G322L or equivalent*
Inner Helicoid	Inner and Outer Surfaces for Slide Housings	Losimol Losoid 72125 B-GE G322L or equivalent*
Aperture Rings	Inside Surfaces	C-Photo Lub 22 or equivalent

*To minimize flare, mix with Molykote Powder, 1 part Moly to 10-15 parts grease.

1.0 DISASSEMBLY OF OPTICAL GROUPS FROM LENS

1.1 FIRST LENS GROUP

- a) Set the lens to 85mm focal length and INFINITY, Fig. 1-1.
- b) Flow solvent (such as Acetone or Methyl-Ethyl Ketone) into the crevice between hood ring (1) and inner focus ring (13), to soften the sealant on their threads. Allow about three minutes for the solvent to work, and then loosen the hood ring. Fig. 1-1.
- c) Set the lens to 55mm focal length position; rotate the focus collar ring to the near focus stop. Fig. 1-2.

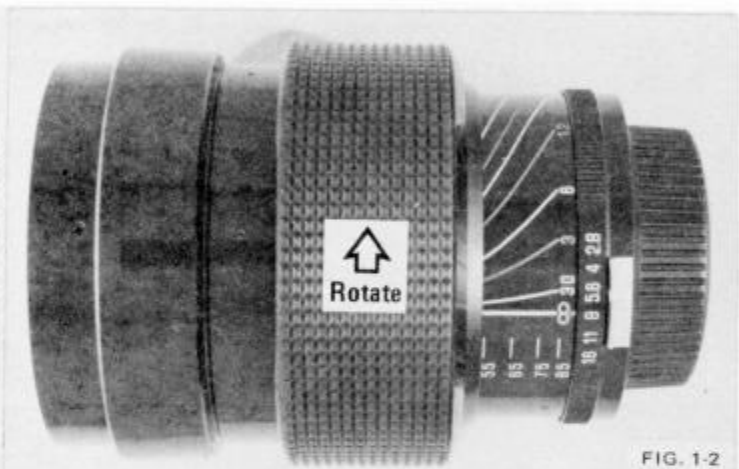
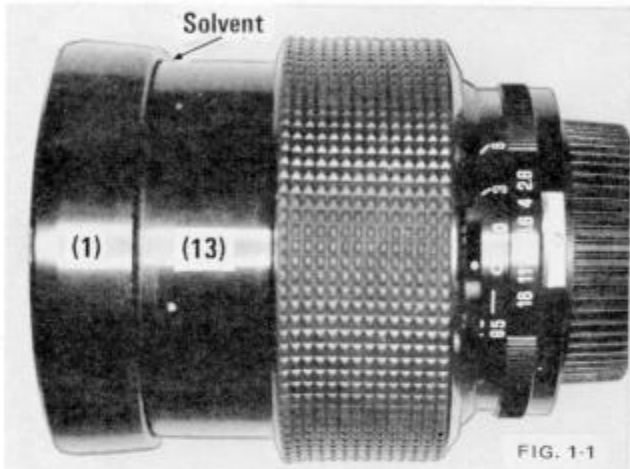

- d) Unscrew the hood ring from the inner focus ring. Fig. 1-3.
- e) Hold hood ring against first lens group and rotate lens to locate setscrew (28), which secures the first lens group to first lens group slide housing (29). Fig. 1-3.
- f) Apply solvent to soften thread sealant; remove the setscrew.

NOTE: On some lenses where the setscrew has been omitted, the first lens group is secured with thread sealant. In this case, flow solvent into the setscrew hole and into the juncture of first lens group housing and its slide housing, until it can be unscrewed from the lens. Fig. 1-4.

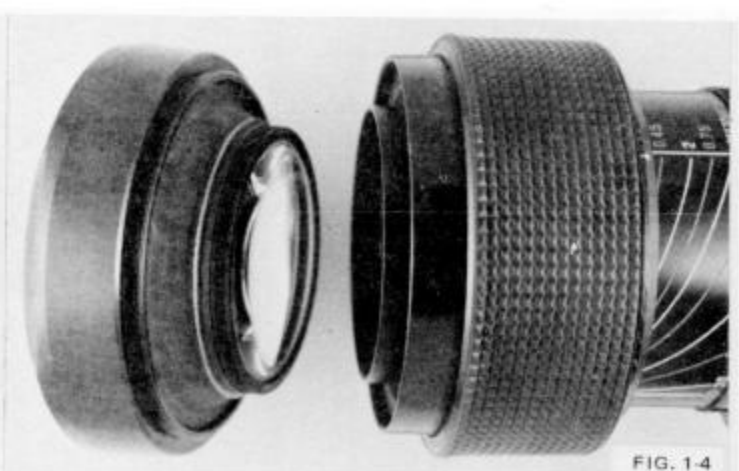
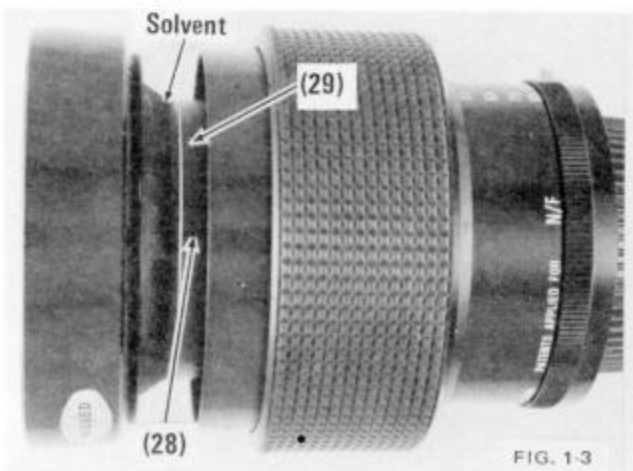

1.2 SECOND LENS GROUP

Second lens group is retained in its housing by four screws (36). Fig. 1-5.

- a) Remove four screws.
- b) Use Tool No. 3650520 to remove second lens group. Place the tool down over the rim of the lens group, tighten the wing nut and remove. Fig. 1-6.

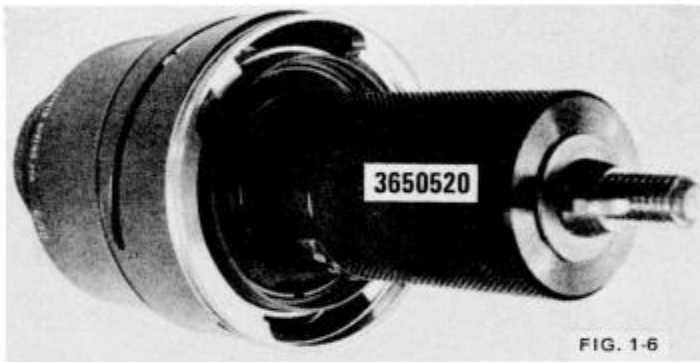
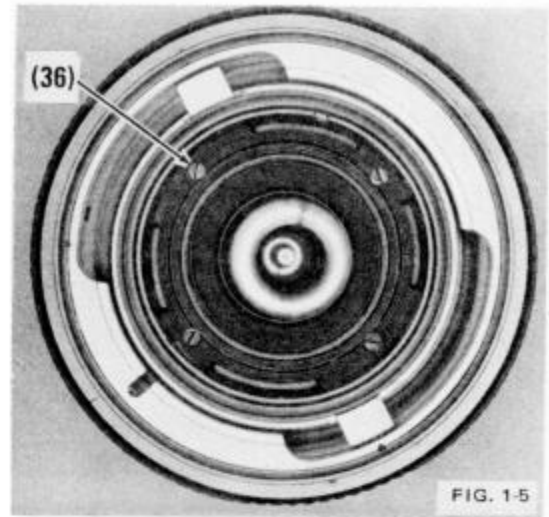

FIG. 1-6

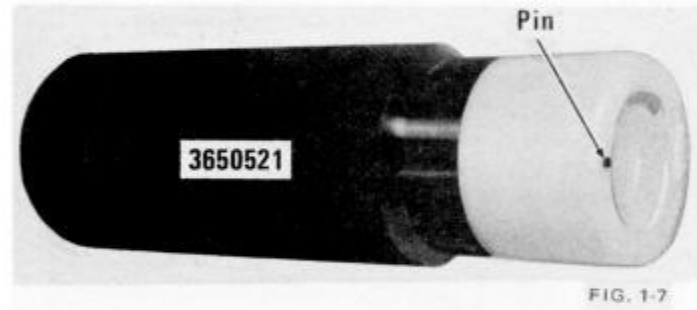

FIG. 1-7

1.3 THIRD LENS GROUP

The third lens group is threaded into slide housing (44). The pin on the rim of Tool No. 3650522 (Fig. 1-7) fits into one of the two holes in the third lens group housing, Fig. 1-8.

- a) Engage pin on tool in hole of lens housing; unscrew and remove.

1.4 FOURTH LENS GROUP

The fourth lens group is not removed except for centering. See Sec. 6.

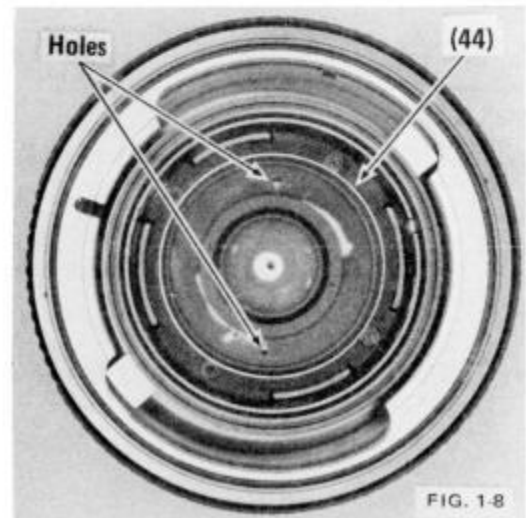

FIG. 1-8

1.5 FIFTH LENS GROUP

Tool No. 3650522 (Fig. 1-9) fits over and clamps to the outer rim of the lens group. Set lens to 85mm focal length position and INFINITY.

- a) Place tool over rear of lens group. Tighten wing nut; unscrew lens and remove it. Fig. 1-10.

NOTE: Watch for focus spacers which usually are located between fifth lens group and diaphragm housing. If loose, lay aside.



FIG. 1-9

2.0 REMOVAL OF LENS MOUNTS FROM LENS

2.1 VIVITAR-UNIVERSAL SERIES THREAD MOUNT

- a) Remove five screws (121); lift off mount (120). Fig. 2-1.

NOTE: Watch for back focus spacers which usually are located between the mount and aperture ring retainer ring. If loose, remove and set aside.

- b) Remove three screws (63) that attach aperture ring retainer ring (100) to mount frame. Fig. 2-2.
- c) Remove setscrew (3); detent spring (99) and detent ball (98) are underneath; remove and set aside. Fig. 2-3.
- d) Remove aperture ring retainer ring (100). Fig. 2-2.

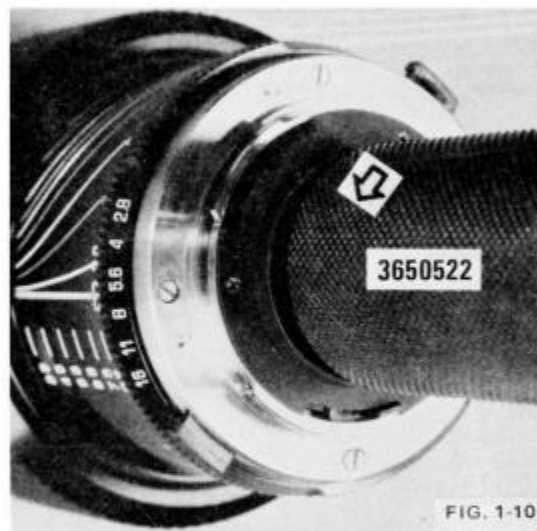

FIG. 1-10

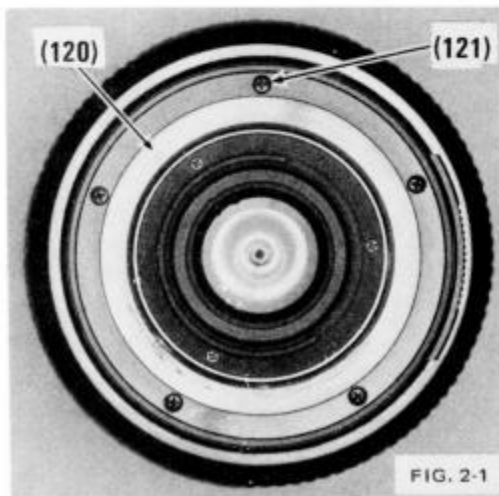

FIG. 2-1

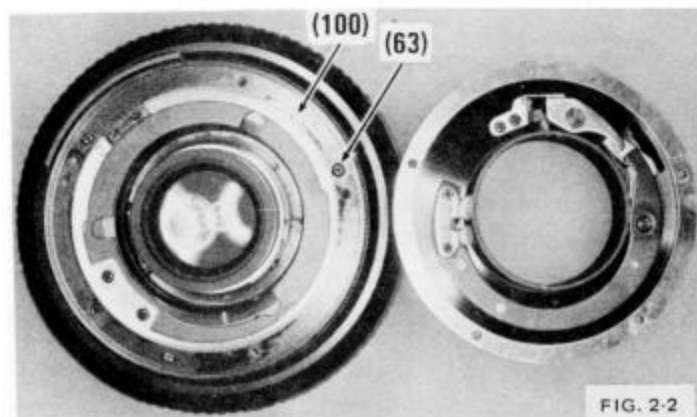
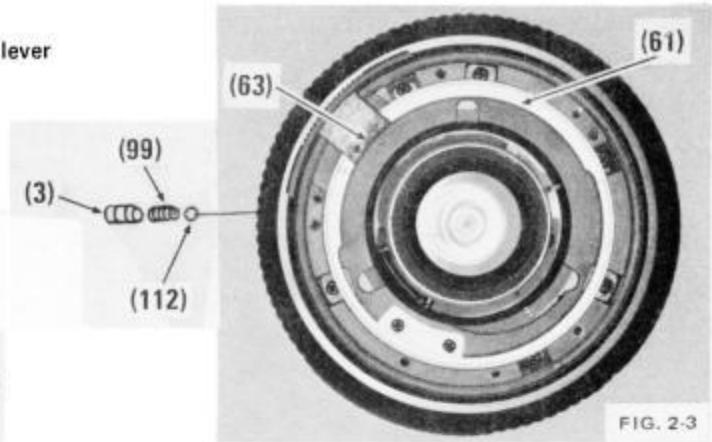
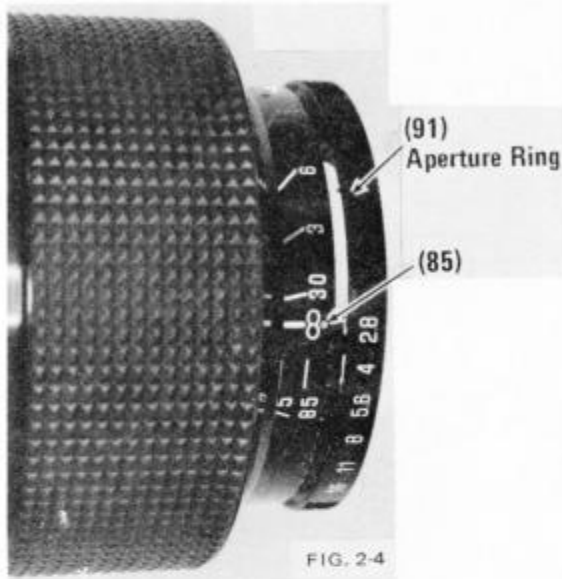

FIG. 2-2

2.1

- e) Remove auto-manual ring (95) with A/M lever (96) attached. Fig. 2-3.
- f) Remove aperture ring (91). Fig. 2-4.



NOTE: There is a detent ball (89) between index ring (85) and aperture ring (91). Remove and set aside.

- g) Position lens so that the infinity index line is at the 12 o'clock position. Remove four screws (87) that attach the mount frame (86) to inner helioid; remove mount frame. Fig. 2-5.

NOTE: There are three cam retainer plates (88). Only the one at the 2:30 position is removed. When reassembling, make sure that curved side is toward cam ring to assure smooth operation.

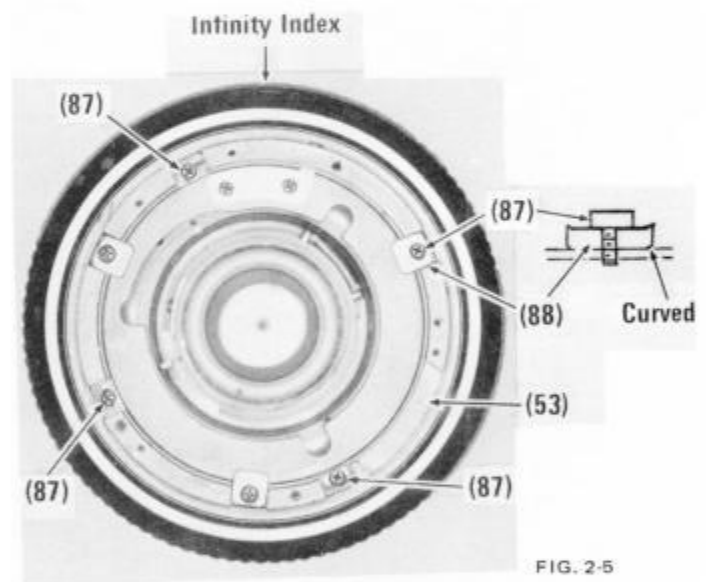

2.1.1 REASSEMBLY (MOUNT TO LENS)

- a) Install the mount frame making sure that the cam retainer plates are correctly installed. (See Note, Instruction 2.1g.)
- b) Place a spot of grease on the detent ball to hold it over the detent spring.
- c) Align tip of cam with slot in aperture ring; install aperture ring over mount frame. Fig. 2-6.
- d) Check operation by rotating aperture ring back and forth.
- e) Install A/M ring.
- f) Install aperture ring retainer ring (100), leaving screws (63) loose. Fig. 2-2.

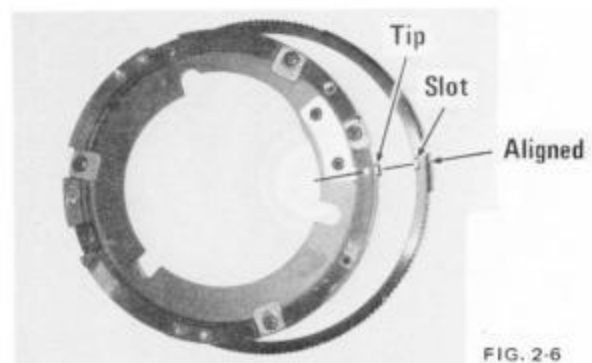

2.1.1

- g) Install A/M ring detent ball, detent spring and setscrew. Adjust detent pressure on A/M ring, then seal setscrew. Fig. 2-3.
- h) Seal and tighten three screws (63). (Instruction 2.1.1f.)
- i) Replace rear mount on lens with back focus spacers as disassembled or as instructed in Sec. 7.0.
- j) Install seven screws (78) attaching mount to lens. Fig. 2-1.

NOTE: Make sure that fork of diaphragm actuator arm engages actuator arm in the diaphragm assembly.

2.2 NIKON F/EL SERIES MOUNT

- a) Remove coupling fork screw (128) and coupling fork (127). Fig. 2-7.
- b) Remove five screws (139); lift off mount (137). Fig. 2-7.

NOTE: Watch for focus spacers which usually are located between the mount and the mount frame. If loose, remove and set aside.

- c) Position the lens so that the infinity index line is at the 12 o'clock position. Remove four screws (87) that attach mount frame (125) to the inner helicoid. Fig. 2-8.

NOTE: The cam retainer plate at the 2:30 position. Refer to Note of Instruction 2.1g when reassembling.

- d) Remove aperture ring (126) and mount frame (125). (Mount frame retains aperture ring in position.) Fig. 2-8.

NOTE: Remove the detent ball (89) located between the index ring (124) and the aperture ring. See Fig. 2-4.

- e) Separate the aperture ring from the mount frame, noting that the tip of the cam ring fits into the slot in the aperture ring. (Instruction 2.1.1c.)

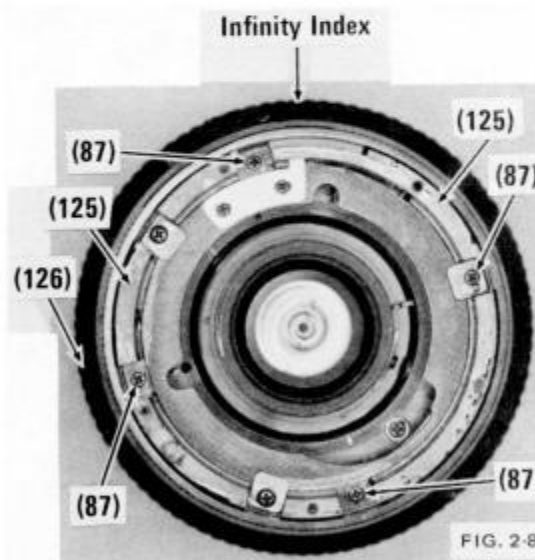
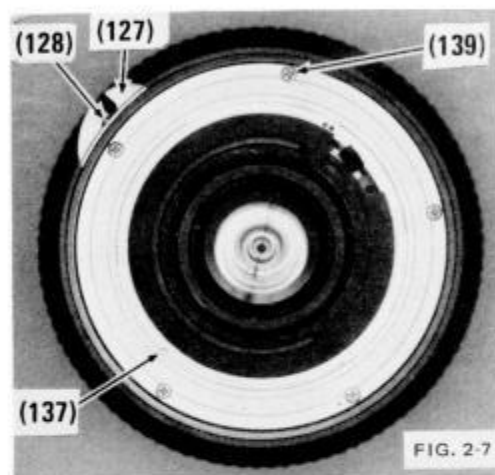

2.2.1 REASSEMBLY (MOUNT TO LENS)

- a) Reassembly is the reverse of disassembly.

NOTE: Make sure that fork of diaphragm actuator arm engages actuator arm in diaphragm assembly.

2.3 MINOLTA SR/XK SERIES MOUNT

- a) Remove four screws (157); lift off mount (156). Fig. 2-9. NOTE: Watch for focus spacers which usually are located between the mount and mount frame. If loose, remove and set aside.
- b) Position the lens so that infinity index line is at the 12 o'clock position. Remove four screws (87) that attach the mount frame (144) to the inner helicoid.

NOTE: The cam retainer plate (88) at the 2:30 position. Refer to Note in Instruction 2.1g when reassembling. Fig. 2-10.

- c) Remove aperture ring (143) and mount frame (144). Mount frame retains aperture ring in position.

NOTE: Remove the detent ball located between the index ring and the aperture ring. See Fig. 2-4.

- d) Separate the aperture ring from the mount frame, noting that the tip of the cam ring fits into the slot in the diaphragm ring as shown in Fig. 2-6.

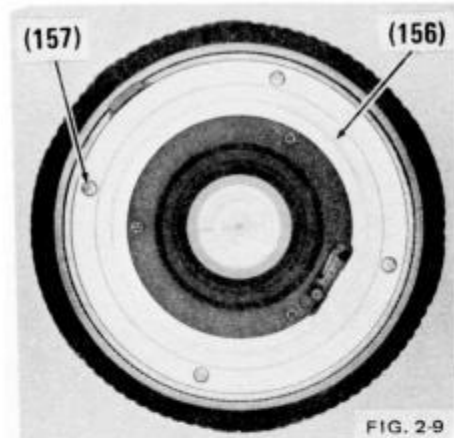

FIG. 2-9

2.3.1 REASSEMBLY (MOUNT TO LENS)

- a) Reassembly is the reverse of disassembly.

NOTE: Make sure that fork of diaphragm actuator arm engages actuator arm in the diaphragm assembly.

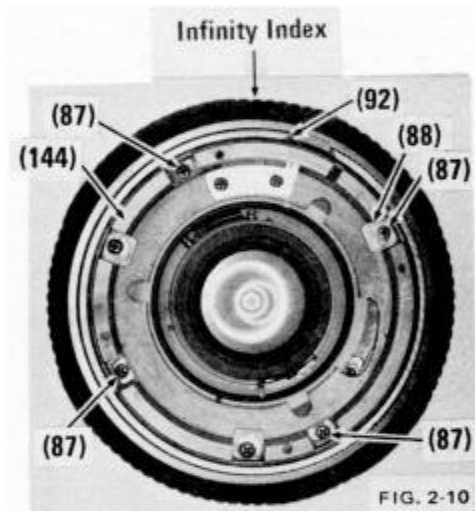

FIG. 2-10

2.4 CANON FL/FD SERIES MOUNT

- a) Set aperture ring to f/16.
- b) Set auto/manual ring (186) to the manual aperture position (fully counter-clockwise position and detented). Fig. 2-11.
- c) Rotate locking ring (192) fully counter-clockwise; remove four mount screws (87). Fig. 2-11.
- d) Rotate locking ring clockwise to the mounting position. (red dot aligned with mounting pin and infinity index line); remove the remaining mount screw. Fig. 2-12.

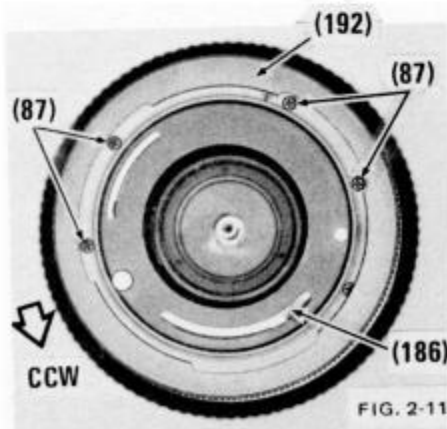

FIG. 2-11

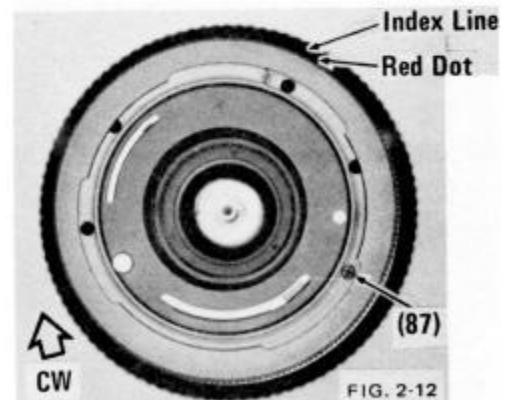

FIG. 2-12

2.4 e) Lift mount from lens.

NOTE: Watch for focus spacers between the mount and mount frame. If loose, lay aside.

f) Remove the EE switch pin (161) and spring (162). Fig. 2-13.

g) Position the lens so that the infinity index line is at the 12 o'clock position. Remove four screws (87) that attach the mount frame (163) to the inner helicoid. Fig. 2-13.

h) Remove aperture ring (160) and mount frame. (Mount frame retains aperture ring in position.) Fig. 2-13.

NOTE: Remove the two detent balls located between the index ring and the aperture ring.

i) Separate the aperture ring from the mount frame, noting that the tip of the cam ring fits into the slot in the aperture ring. Fig. 2-14.

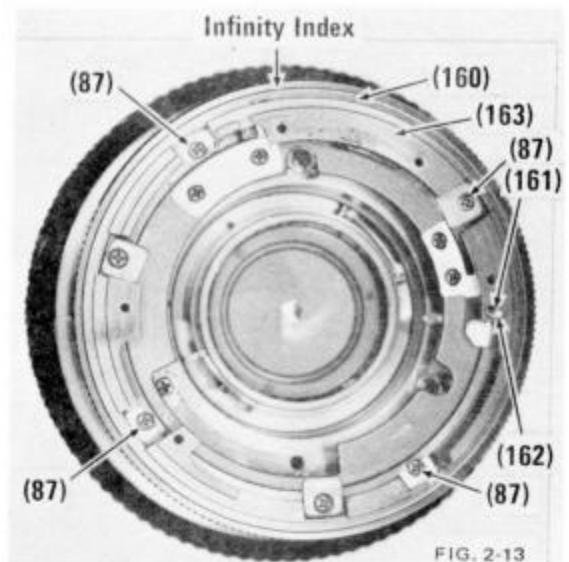

FIG. 2-13

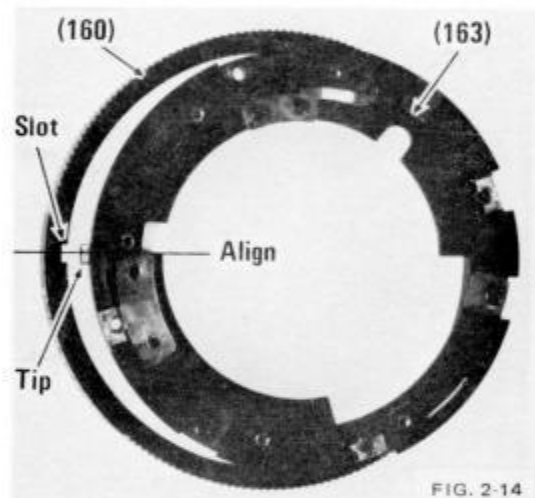

FIG. 2-14

2.4.1 REASSEMBLY (MOUNT TO LENS)

a) Reassembly is the reverse of disassembly.

NOTE: Make sure that fork of diaphragm actuator arm engages actuator arm in the diaphragm assembly.

2.5 KONICA AUTOREFLEX SERIES MOUNT

a) Remove three screws (21) and shade pipe (217). Fig. 2-15.

b) Remove four screws (157); lift off mount in an upward angled movement, so that mount clears tab on aperture ring (203). Fig. 2-15.

NOTE: Watch for focus spacers which usually are located between the mount and mount frame (B) assembly. If loose, set them aside.

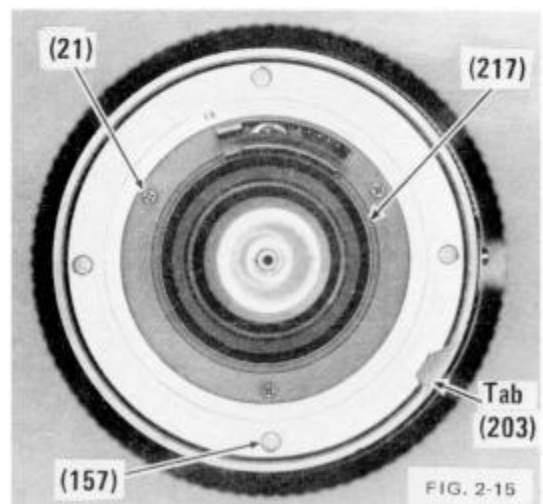

FIG. 2-15

2.5

- c) Remove four screws (207); lift mount frame (B) assembly (206) upwards and away from lens. Fig. 2-16.
- d) Remove aperture ring (203) from mount frame.

NOTE: Remove detent ball located between index ring and aperture ring.

- e) Position the lens so that the infinity index line is at the 12 o' clock position. Remove three screws (87) and change latch screw (197), that attaches EE change latch (530) to the lens, and threads into the outer helicoid. Fig. 2-17.

NOTE: The cam retainer plate (195) at the 2:30 position is mounted in reverse to the other retainer plates and has a thin washer underneath. Fig. 2-17A.

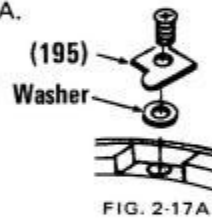

FIG. 2-17A

CAUTION: If, during reassembly, this retainer plate is improperly installed, incorrect diaphragm action will result.

- f) Lift off mount, mount frame (A) (194). Fig. 2-18.

2.5.1 REASSEMBLY

- a) Place mount frame (A) (194) on the lens so that EE change latch cutout aligns with lens mounting index dot on index ring. Fig. 2-18.
- b) Align the holes in mount frame with the holes in the outer helicoid.
- c) Install change latch screw (197), EE change latch (530), and spring (219). Hook end of spring on spring post (71). Fig. 2-17.
- d) Install screws (87) in the mount frame at the 11:30, 2:30 (with cam retainer plate), and 5:30 positions. Fig. 2-17.

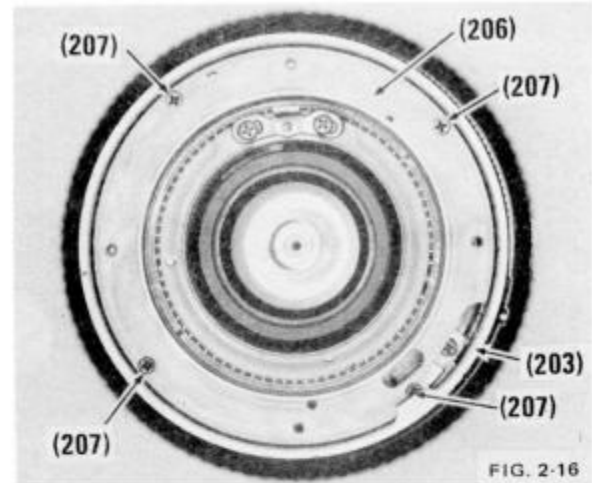

FIG. 2-16

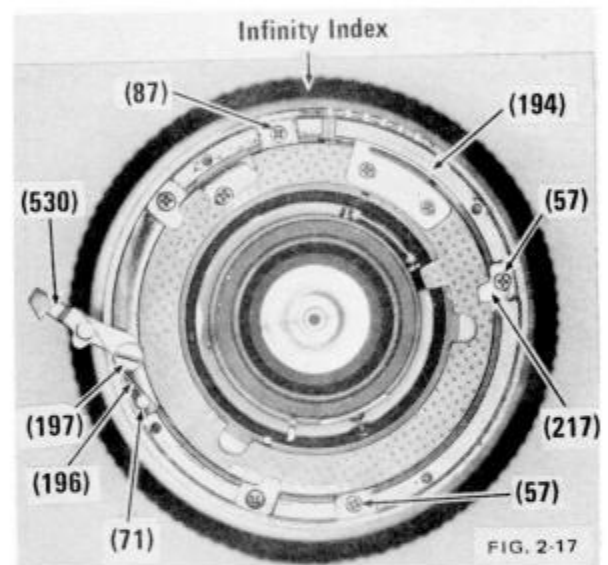

FIG. 2-17

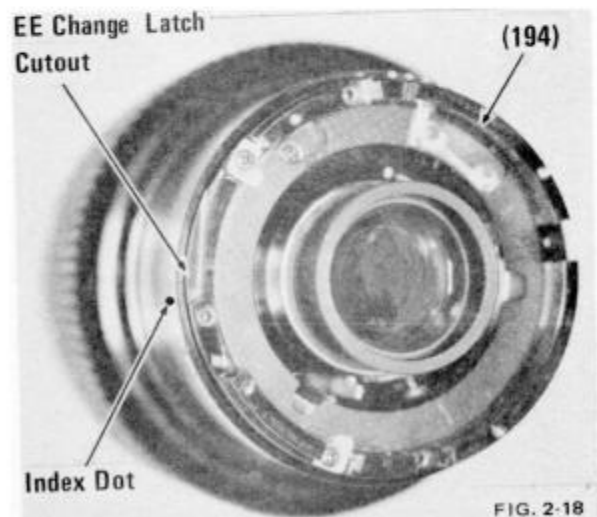

FIG. 2-18

2.5.1

- e) Place a spot of grease on the detent ball to hold it over the detent spring and, while holding EE change latch so that aperture ring will clear it, place aperture ring down over mount frame (A), ensuring engagement of slot in aperture ring with tip of plate on aperture cam ring (199). Fig. 2-19.

With aperture ring set to EE position and locked, set mount frame (B) assembly into position so that fork (112) on diaphragm lever engages diaphragm actuating arm (51) and cutout passes over tab on diaphragm ring. Fig. 2-20.

Align screw holes; place thread sealant on screw threads and install screws.

Replace rear focus spacers as disassembled, between mount frame assembly (B) and mount when installing mount to lens.

NOTE: Further disassembly of the mount is seldom required, but will be obvious if found necessary.

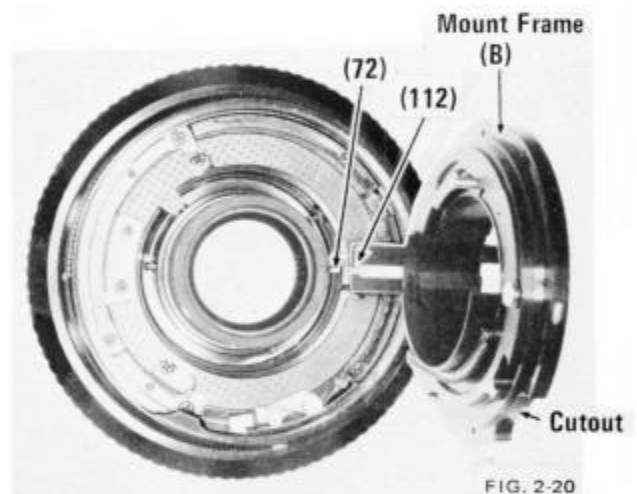
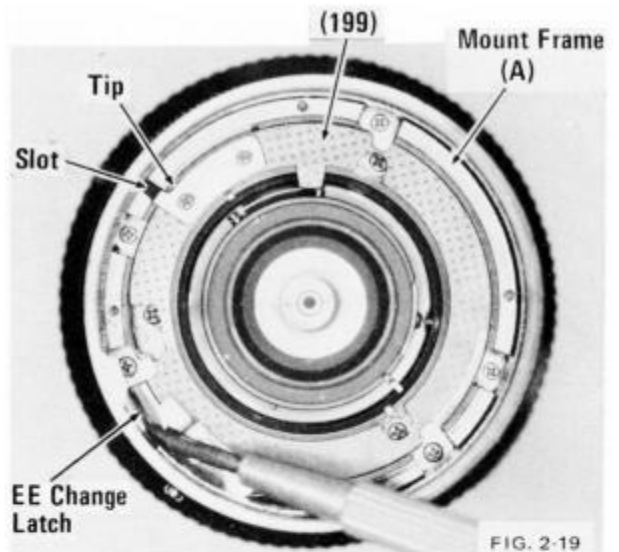

2.6 OLYMPUS OM-SERIES MOUNT

- a) Remove four screws (257); lift off mount (253). Fig. 2-21.

NOTE: Watch for focus spacers which usually are located between the mount and the mount frame. If loose, remove and set aside.

- b) Remove aperture ring retainer ring (227). Use Tool No. 3650529. Fig. 2-22.

NOTE: When re-installing retainer ring; adjust it so that aperture ring rotates freely. Seal with thread sealant.

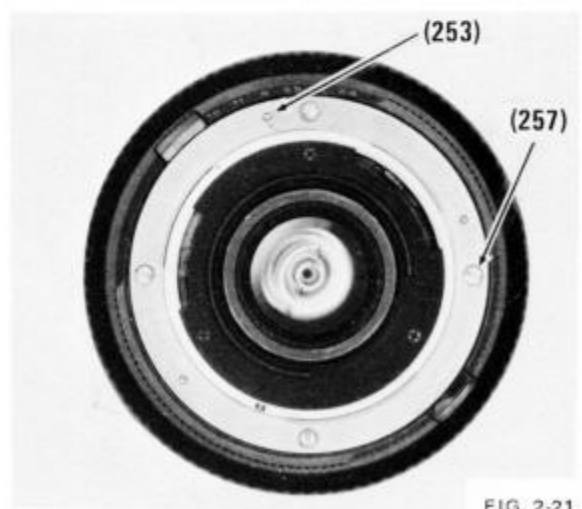

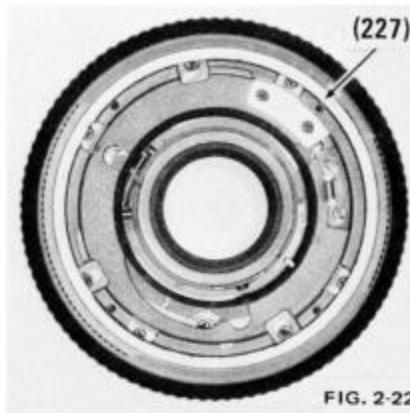

FIG. 2-22

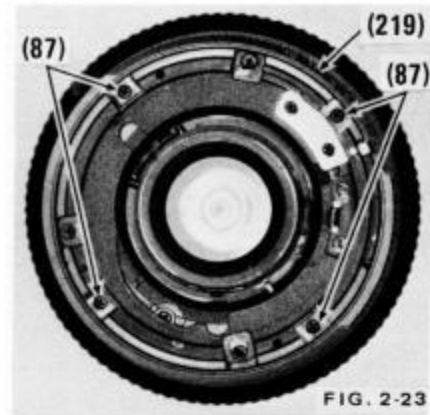

FIG. 2-23

- c) Remove aperture ring (219). Fig. 2-23. Remove and lay aside the detent ball located between the index ring and the aperture ring.
- d) Remove four screws (87) that attach mount frame (220) to the lens. Fig. 2-23.

NOTE: In this mount, there is no cam retainer plate held by a mount frame screw.

2.6.1 REASSEMBLY

Reassembly is the reverse of disassembly.

NOTE: Make sure that fork of diaphragm actuator arm engages actuator arm in the diaphragm assembly.

3.0 PRIME LENS ASSEMBLY

The prime lens assembly consists of the 4th and 5th lens groups, mounting rings, diaphragm housings, diaphragm blades, blade ring, and blade operating ring mount as shown in Fig. 3-1.

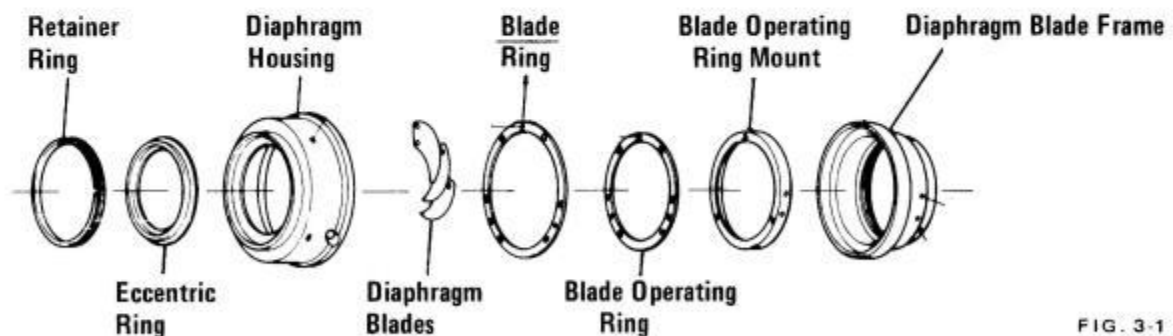

FIG. 3-1

Repairs to the prime lens assembly are infrequent. Removal of the assembly in order to perform other service procedures on the lens as well as complete instructions for disassembly/reassembly are included in this section.

3.1 REMOVAL OF PRIME LENS

Remove fifth lens group from prime lens assembly, then proceed as follows:

- a) With the lens positioned so that the infinity index line is at the 12 o'clock position, using tool No. 3650536 place a scribe line extending across outer helicoid (53), inner helicoid (47) and front diaphragm housing (60). Fig. 3-2.

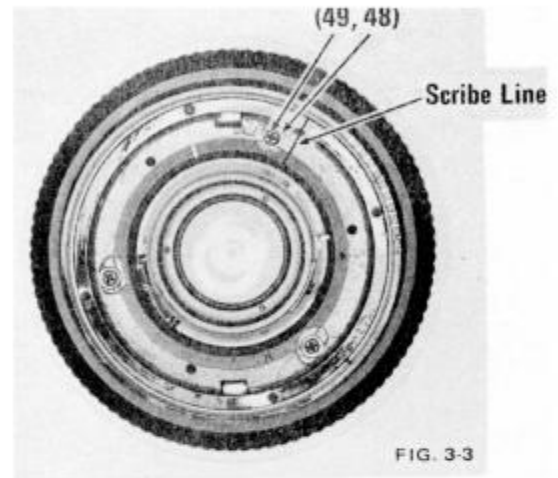
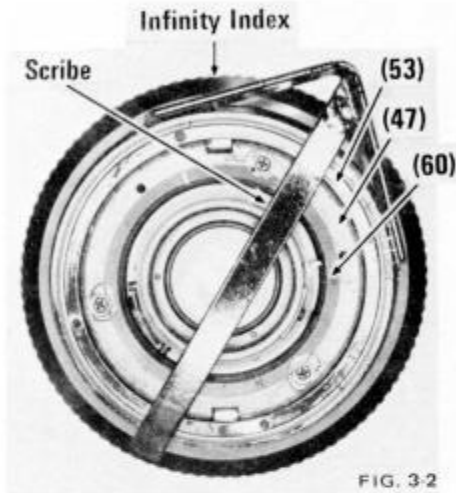

- b) Remove three screws (29) and three washers (28) that hold diaphragm housing in inner helicoid. Fig. 3-3.

- c) Screw fifth lens group into rear diaphragm housing (70) and lift the assembly from the inner helicoid. Fig. 3-4.

3.2 REPLACEMENT

- a) Insert diaphragm housing assembly into inner helicoid; align scribe marks (Instruction 3.1a).
- b) Replace washers (28) and screws (29). Seal and tighten the screws. Fig. 3-3.

NOTE: If it is necessary to install a new diaphragm housing, there will be no scribe reference line. See Sec. 3.5 for procedures.

3.3 DISASSEMBLY

- a) Remove fifth lens group and any spacers found between the lens group and the rear diaphragm housing (70). (Usually two or three of 0.12mm thickness.) Fig. 3-4.
- b) Refer to Sec. 6.7; check centering of 4th lens group in diaphragm housing.

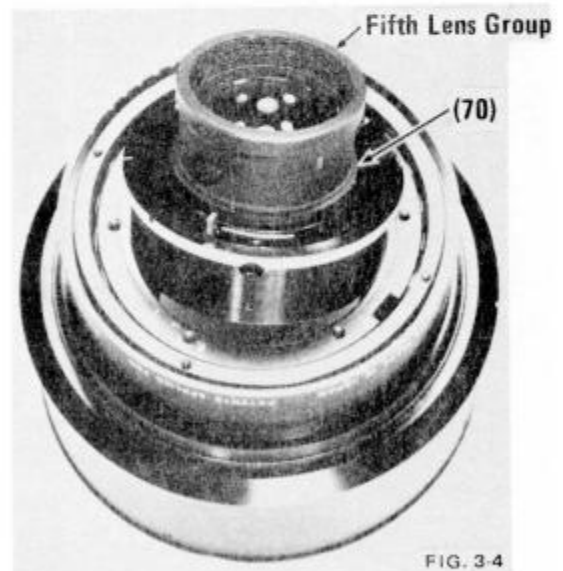

CAUTION: Do not omit this procedure, as performance of the lens will be impaired if the rear diaphragm housing is not accurately re-centered on reassembly.

- 3.3 c) Remove three setscrews (28), which clamp rear diaphragm housing into front diaphragm housing.
- d) Screw fifth lens group, or Tool No. 3650557 into rear diaphragm housing. Gently work front diaphragm housing away from rear diaphragm housing. Fig. 3.6.
- e) Remove diaphragm blades from rear diaphragm housing.
- f) Clean diaphragm blades and diaphragm housing thoroughly. An ultrasonic cleaner is recommended.

NOTE: This procedure is applicable only to old style diaphragm housings held together by setscrews (28). New style diaphragm housings are screwed together. Center lens as described in Paragraph 6.7.

3.4 REASSEMBLY

- a) Install diaphragm blades in a clockwise sequence. Fig. 3-6.
- b) Clean fourth lens group surfaces; remove spot of cement on inside of front diaphragm housing, placed during initial assembly.
- c) Align blade ring limit stop access hole in front diaphragm housing with head of aperture limit plate stop screw (50); install front diaphragm housing over rear diaphragm housing, seating it firmly. Fig. 3-6.
- d) Holding parts firmly together, install the three setscrews (17) in front diaphragm housing. Thread the setscrews into the housing until they just make contact with the rear diaphragm housing.
- e) Refer to Section 6.7; place the diaphragm housing assembly on the centering tool under the microscope. Tool No. 3650528.
- f) Tighten the three setscrews so that the centering of the fourth lens is exactly as it was before disassembly.
- g) Thread Tool No. 3650557 into rear diaphragm housing; hold diaphragm lever against limit stop and measure the aperture size. At f/16, the diaphragm blades should just touch the pin of the tool. (Diameter of the opening is $3.5 \pm 0.2\text{mm}$.) Fig. 3.7. Adjust the aperture size by shifting the position of limit stop plate (49). Fig. 3-6.

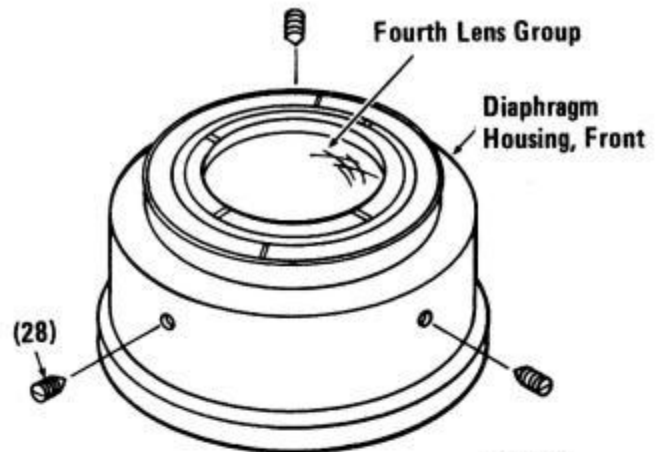

FIG. 3-5

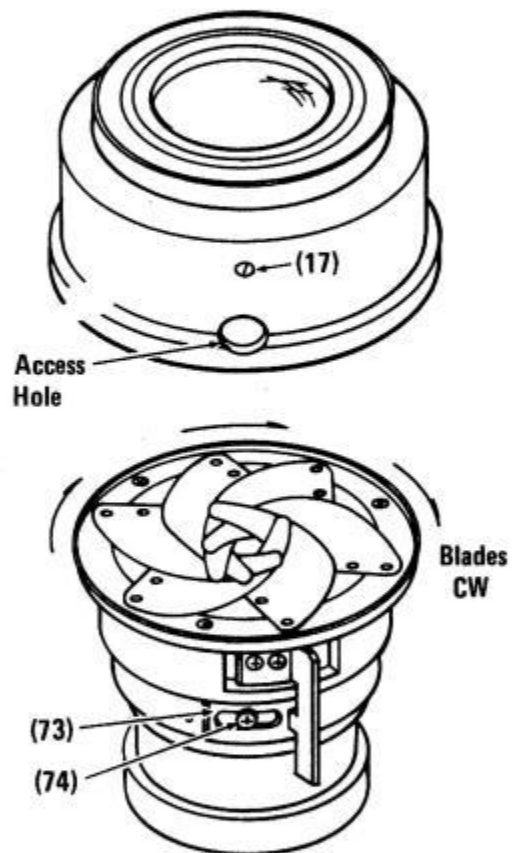

FIG. 3-6

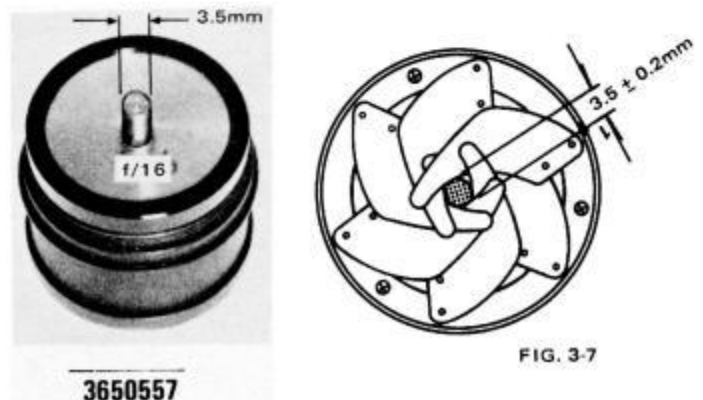

FIG. 3-7

3.5 INSTALLING A NEW DIAPHRAGM HOUSING ASSEMBLY

If a new diaphragm housing assembly is to be installed, or if a new inner helicoid is installed, there will be no scribe lines to align. Proceed as follows:

- a) Install diaphragm housing assembly in the assembled lens; ensure that the housing is free to rotate by loosening screws (49). Fig. 3-7.
- b) Remove shade pipe from the Universal Thread Series Mount, and the N, M, and O mounts. Remove the f/stop setting ring of the Konica Mount.

NOTE: Do not remove shade pipe (528) from Canon FL/FD Series Mount.

- c) Set lens to 35mm focal length and infinity position.
- d) Place the angle setting tool No. 3650535 over the rear of the lens as shown in Fig. 3-9.
- e) Rotate the tool until the correct scribed angle setting line for the lens is aligned with the center of the infinity index line. Fig. 3-9.
- f) Rotate diaphragm housing assembly to align diaphragm actuator arm (72), in the f/16 position, with the pointer. Fig. 3-10.

- g) Tighten screws (49) very slightly to hold the diaphragm housing assembly as set.
- h) Assemble the mount frame to the lens. Seal the mount frame screws and tighten them.
- i) Assemble the mount to the lens (be sure the fork is engaged with diaphragm actuator arm).
- j) Set the aperture ring to f/16.

- k) Adjust the position of the diaphragm housing assembly so that operation of the diaphragm is correct at all f/stops and half-stops. Proceed as follows:

1. Set aperture ring to f/16, then rotate it slowly toward the f/11 position. The diaphragm blades should begin to open almost as soon as the ring is moved, and there should be a significant change in aperture between the f/16 and one-half stop open from the f/16 setting.
2. Adjust position of diaphragm housing assembly to obtain correct operation.

- l) When the position of the diaphragm housing assembly is correctly adjusted, remove the mount, rotate the aperture ring to expose screws (49), seal and tighten.

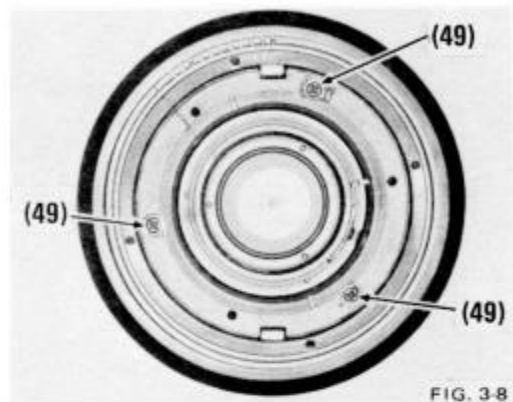

FIG. 3-8



FIG. 3-9

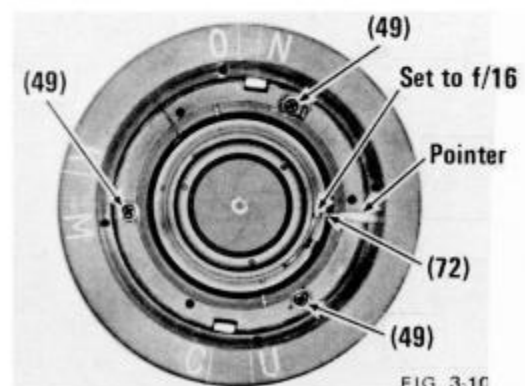
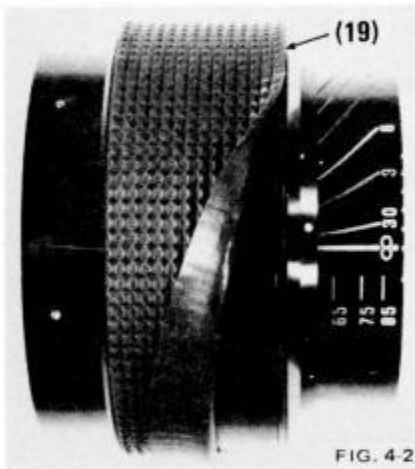
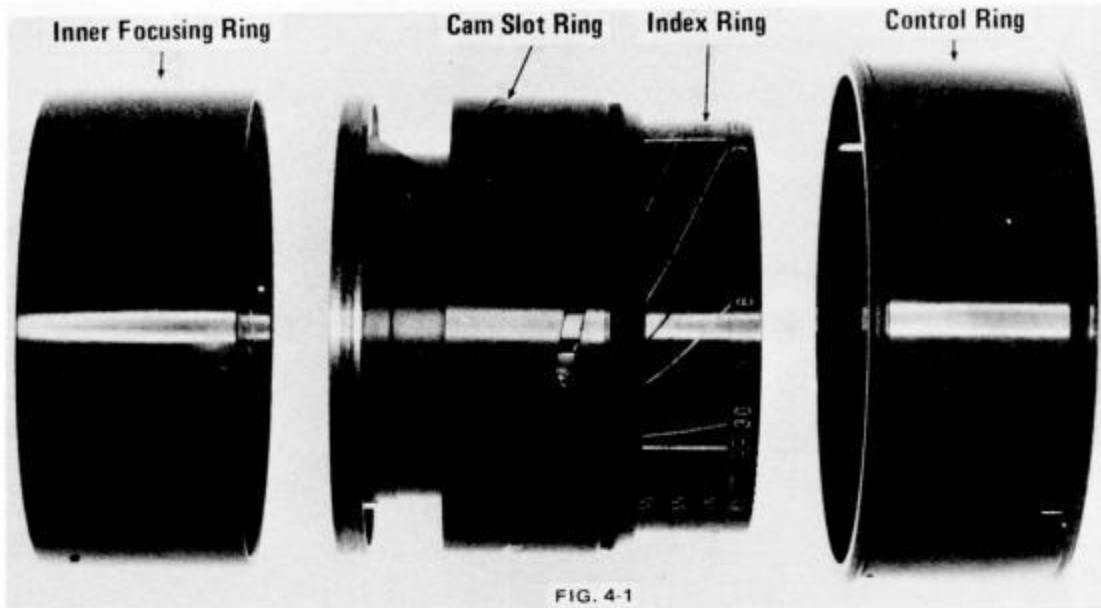

FIG. 3-10

4.0 DISASSEMBLY OF MAIN LENS

4.1 CONTROL HOUSING (Parts are shown in Fig. 4-1.)



a) Remove grip (19) by rolling it off "like a stocking." Fig. 4-2.

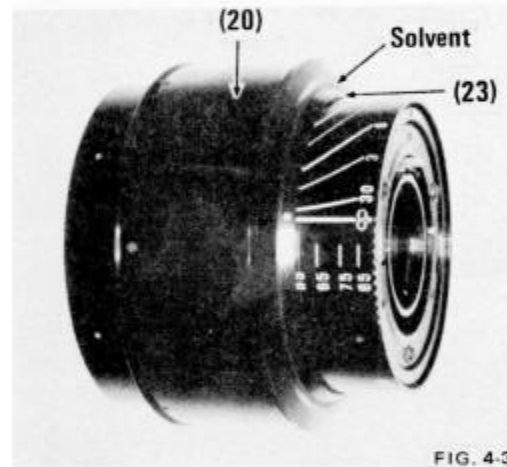

b) Flow solvent into threads between control ring (20) and cam slot ring (23). Fig. 4-3.

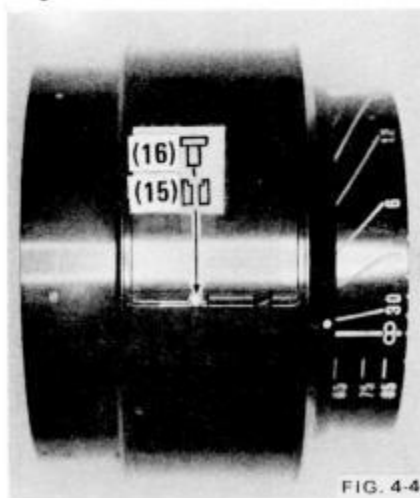

c) Remove control ring roller shaft (16) and roller (15) from each side of lens. Fig. 4-4.

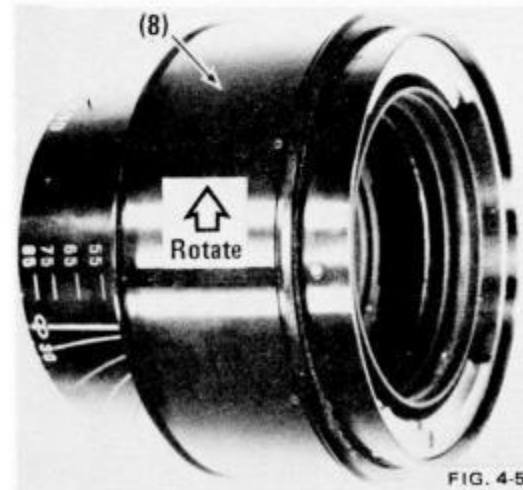

d) Hold rear of lens in left hand, rotate control ring (20) clockwise until it stops. Back rotate slightly, and with a quick forward snap-of-the-wrist, spin control ring off cam ring, and remove towards rear of lens.

4.1

- e) Remove six setscrews (14), that attach inner focusing ring (13) to the lens. Slide focusing ring off front of lens. Fig. 4-6.
- f) Remove bridge ring roller shaft (27) and bridge ring roller (26) from each side of lens. Slide cam ring (23) off to rear of lens. Fig. 4-6.

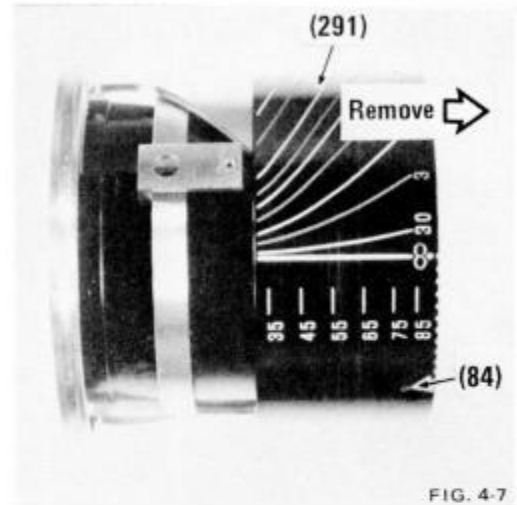
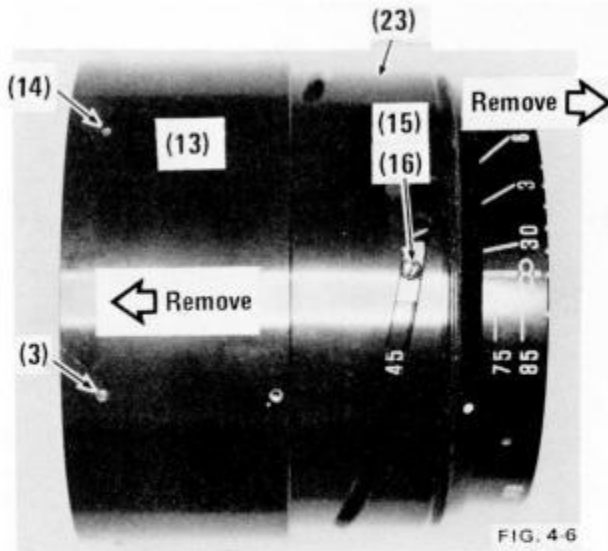

- g) Remove three setscrews (84); slide index ring (291) off to rear of lens, as shown in Fig. 4-7.

4.2 HELICOID ASSEMBLY

The helicoid assembly consists of the outer helicoid, middle helicoid, inner helicoid assembly, bridge ring, helicoid guides, and infinity stop plate. Disassemble in the following order:

- a) Remove flat head screws (2) that attach bridge ring (25) to the inner helicoid assembly. Fig. 4-8.

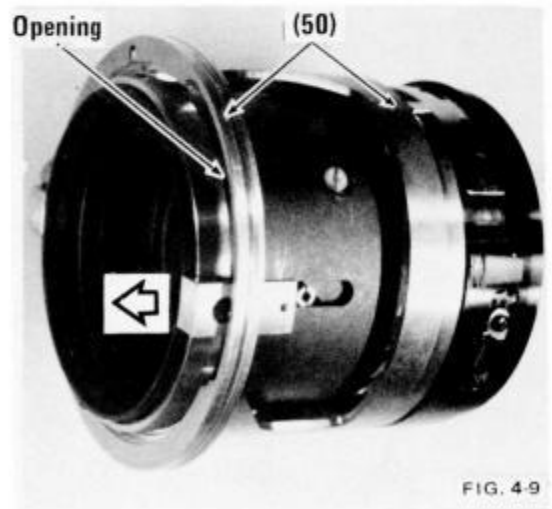
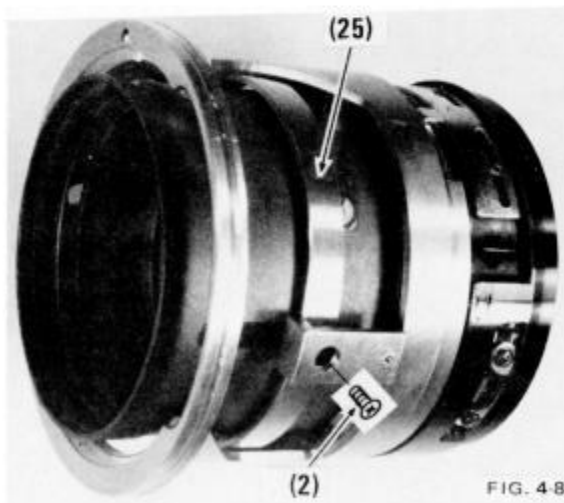

- b) Pass bridge ring out through the opening of the middle helicoid (50) in the direction of the arrow. Fig. 4-9.

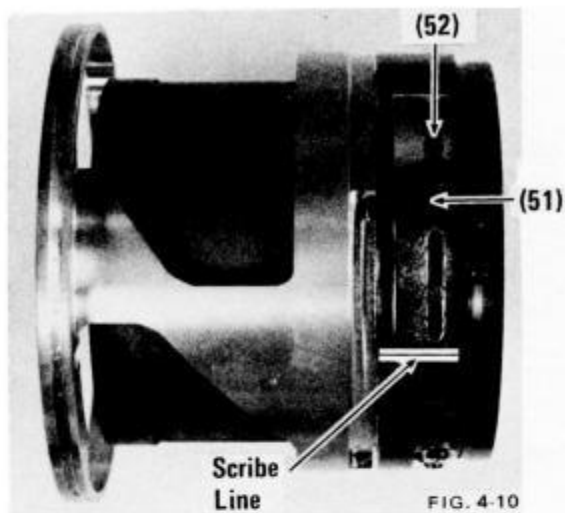

- c) Place a scribe line along edge of infinity stop plate (51). Remove two screws (52) and the stop plate. Fig. 4-10.

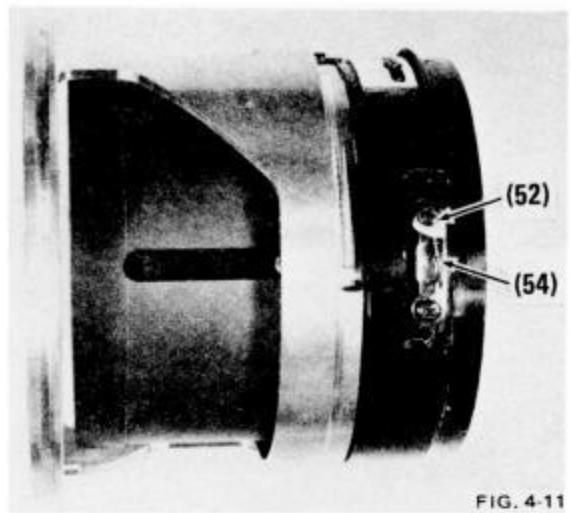

- d) Remove two screws (52) and helicoid guide (54) from each side of the lens. Fig. 4-11.

- e) Rotate inner helicoid assembly free from middle helicoid (50). Unscrew outer helicoid (53) from middle helicoid. Fig. 4-12.

Inner Helicoid
Assembly

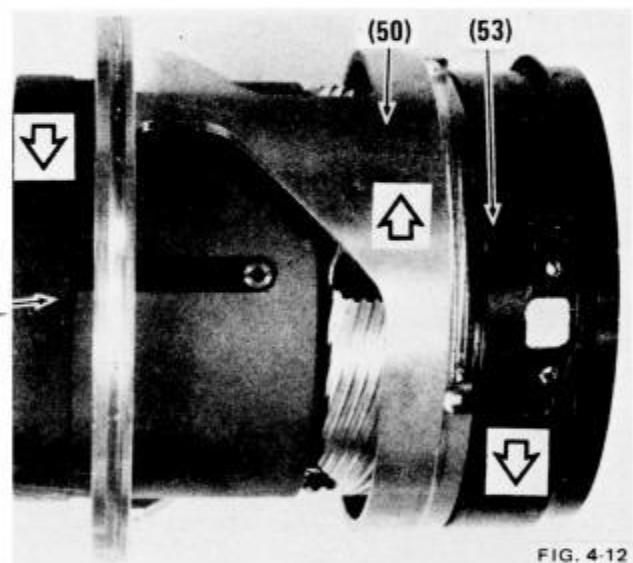

4.2.1 ALTERNATE METHOD TO SEPARATE INNER HELICOID ASSEMBLY FROM MIDDLE HELICOID

- a) Place a scribe line along edge of infinity stop plate (51). Remove two screws (52) and stop plate. Fig. 4-10.
- b) Grasp middle helicoid (50) and outer helicoid (53); rotate in direction of arrows until inner helicoid clears helicoid guides. Fig. 4-12.
- c) Rotate inner helicoid assembly free from middle helicoid.
- d) Unscrew outer helicoid (53) from middle helicoid with helicoid guides attached.

4.3 INNER HELICOID ASSEMBLY

The inner helicoid assembly consists of inner helicoid, first lens group slide housing, second lens group slide housing, third lens group slide housing and the roller shafts and rollers.

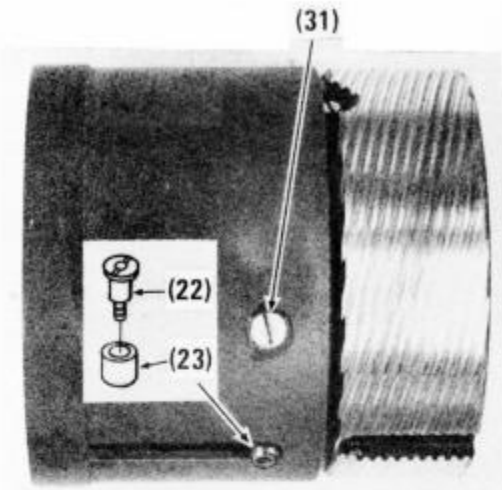

FIG. 4-13

a) Remove 1st lens group slide screw (31) two places. Use tool No. 3650533 to remove 2nd lens group slide shaft (39) and roller (38) (two places). Fig. 4-13.

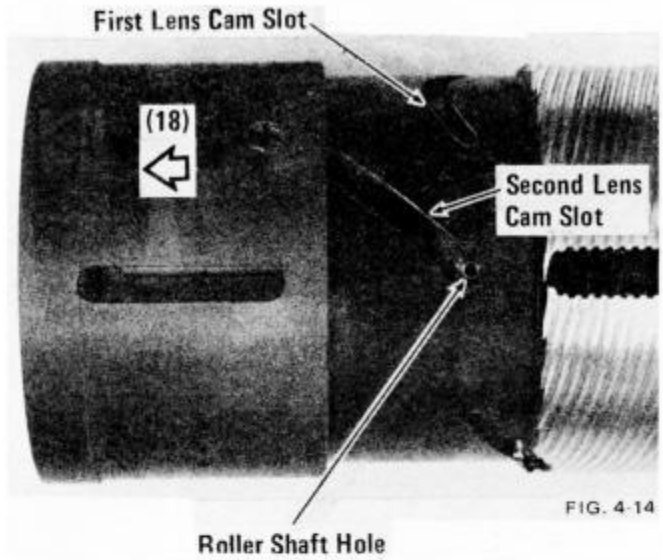

FIG. 4-14

b) Slide 1st lens group slide housing (29) off inner helicoid as shown in Fig. 4-14.

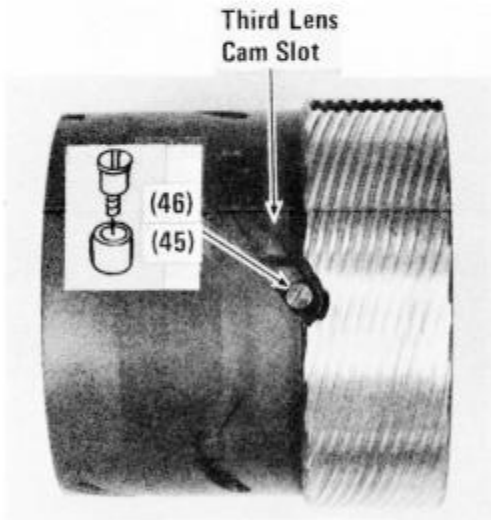

FIG. 4-15

c) Remove roller shaft (46) and roller (45) (two places) from third lens cam slot.

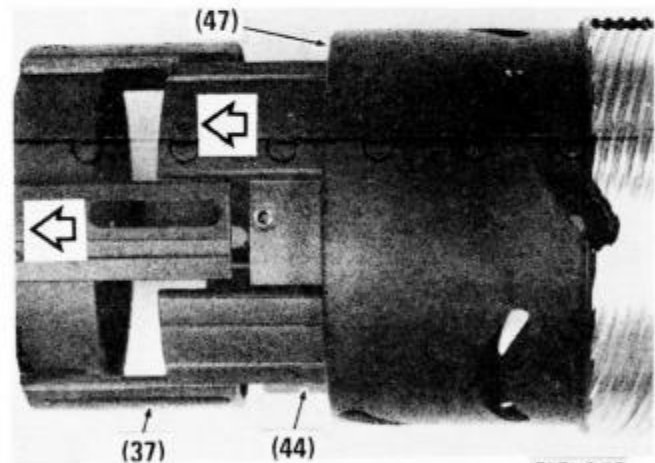

FIG. 4-16

d) Slide 2nd lens group slide housing (37) and 3rd lens group slide housing (44) out front of inner helicoid (47). Fig. 4-16.

4.4 CLEANING OF HELICOIDS AND SLIDE HOUSINGS

Clean helicoids and slide housings in a clean solvent such as Trichloroethylene, Freon, or Perchloroethane. Remove all old lubricant and dirt which may be on the parts.

4.5 LUBRICATION OF HELICOID ASSEMBLY

Lubrication is described below, however, the sequence of lubrication is given in the reassembly procedure and should be accomplished when specified. Refer to Fig. 4-17.

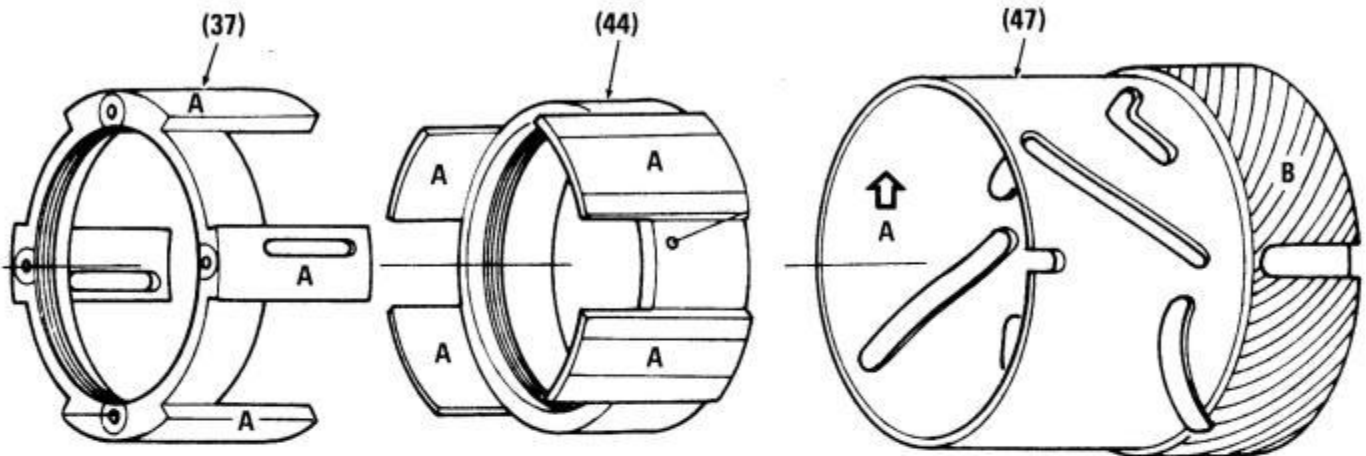

FIG. 4-17

- a) Apply a thin film of lubricant "A" to the inside of inner helicoid (47).
- b) Apply a thin film of lubricant "A" to the bearing surfaces of slide housings (37) and (44).
- c) Insert slide housings into inner helicoid. Slide and rotate them back and forth to spread lubricant evenly over all surfaces.
- d) Remove slide housings, wipe off excess lubricant.

- e) Apply a thin film of lubricant "B" to threads of inner helicoid (47) (Fig. 4-17) and middle helicoid (50), Fig. 4-18.

Assemble the helicoids; rotate back and forth to spread lubricant evenly. Separate the helicoids and wipe off excess lubricant.

- f) Apply a thin film of lubricant "B" to the threads of outer helicoid (53) and to the mating threads on middle helicoid. Assemble, rotate back and forth to spread lubricant evenly. Separate the helicoids and remove excess lubricant. Fig. 4-18.

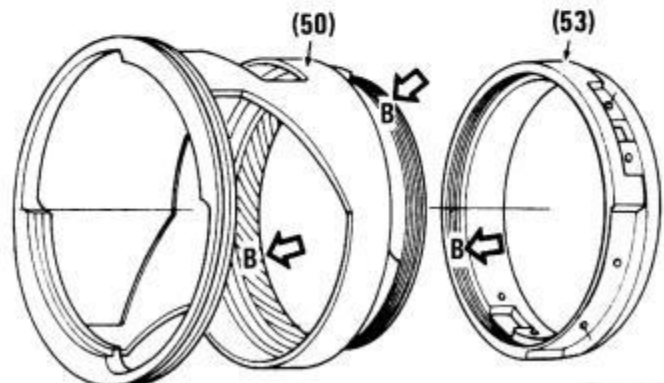

FIG. 4-18

4.5

- g) Apply a thin film of lubricant "A" to the bearing surfaces of 1st lens slide housing (29). Slide the housing onto inner helicoid; rotate and slide it back and forth to spread the lubricant evenly over the surfaces. Separate and wipe off excess lubricant. Fig. 4-19.

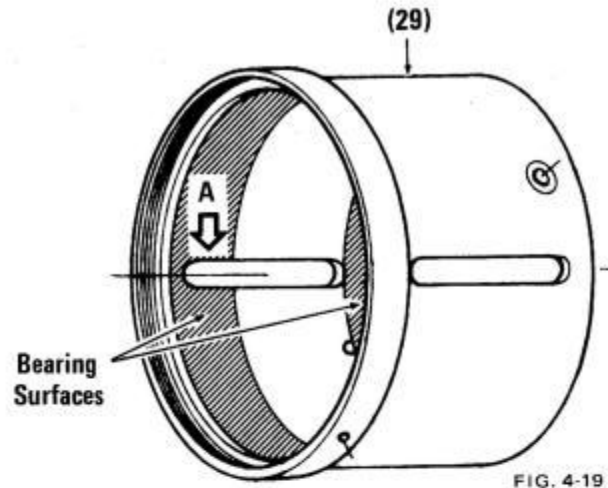

FIG. 4-19

CAUTION: Wipe off all excess lubricant from threads and sliding components of the lens. Too much lubricant has a way of creeping onto parts, such as diaphragm blades, which must remain dry.

5.0 REASSEMBLY OF MAIN LENS

The inner helicoid has four pairs of slots milled into it as shown in Fig. 4-20. In the reassembly instructions which follow, references will be made to these slots. Figure numbers shown in disassembly are referred to in reassembly.

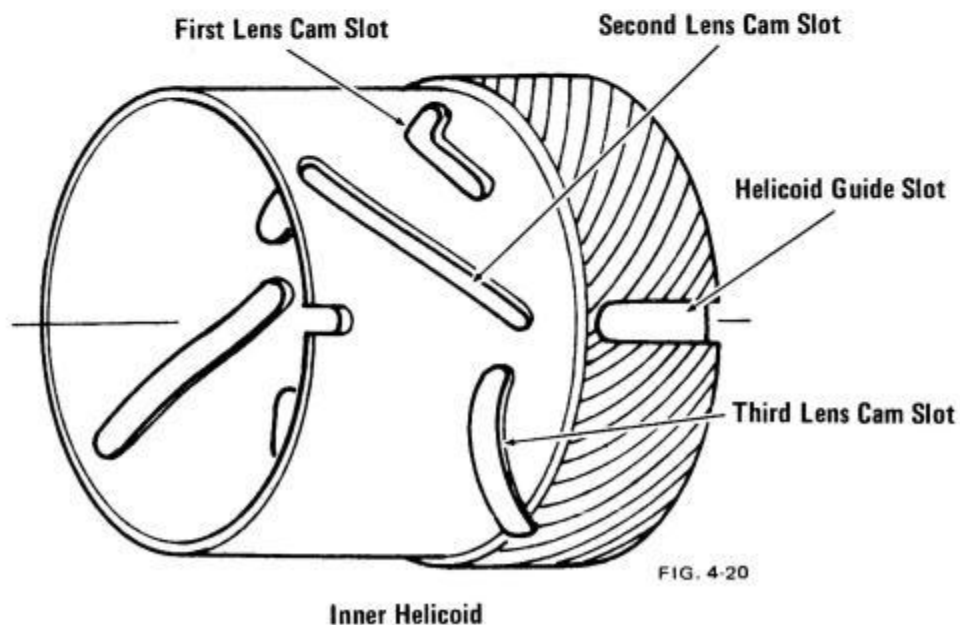

FIG. 4-20

5.0

There are two types of inner helicoids used in the lens. In Type I the edges of the first lens group cam slot, and the sides of the slide screws (31) are beveled. Fig. 4-21.

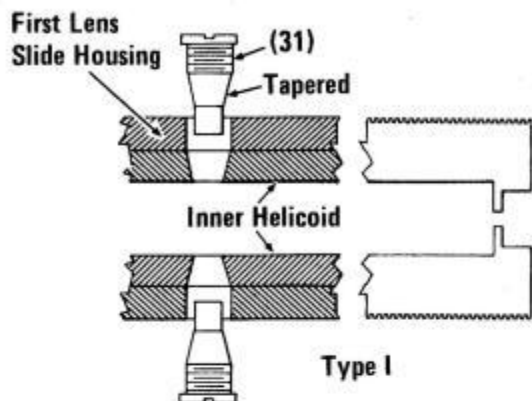

FIG. 4-21

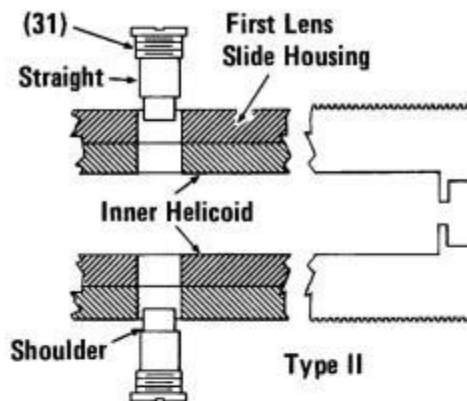

FIG. 4-22

In Type II the edges of the first lens cam slot, and the sides of slide screw (31) are straight. Fig. 4-22.

THE TAPERED SCREWS AND THE STRAIGHT SCREWS ARE NOT INTERCHANGEABLE. Incorrect use will result in improper operation.

5.1 INNER HELICOID

- a) Lubricate inside of inner helicoid and slide housings as instructed in Section 4.5a and 4.5b.
- b) Assemble second lens slide housing (37) to third lens slide housing (24) so that short slot in (21) aligns with roller shaft hole in (44). Fig. 4-23.
- c) Insert the slide housings into inner helicoid so that third lens slide housing (44) enters inner helicoid first. Fig. 4-16.
- d) Align roller shaft hole of third lens housing (44) with third lens cam slot of inner helicoid; install roller shaft (46) and roller (45) on each side, sealing the threads with thread sealant. Fig. 4-15.
- e) Lubricate 1st lens slide housing as instructed in Section 4.5g. Slide housing onto inner helicoid, aligning straight slot with roller shaft hole in 2nd lens slide housing.
- f) Install 2nd lens roller shaft (39) and roller (38) through slot in 1st lens slide housing and into roller shaft hole in 2nd lens slide housing. Fig. 4-14 and 4-13.
- g) Install 1st lens slide screw (31) in its mounting hole, through first lens cam slot in inner helicoid and into long slot in 2nd lens slide housing. Repeat for other side of lens. Fig. 4-13.

5.1

h) Adjust the depth of slide screw (31) in the assembly as follows:

1. Type I Helicoid. Fig. 4-21.

- a) Place a small quantity of thread sealant on the threads of the screws.
- b) Tighten the screws until they just touch the sides of the cam slot; then while rotating the 1st lens slide housing back and forth, adjust the depth of the screws to obtain minimum fore and aft play while assuring smooth, easy rotation of the housing.

2. Type II Helicoid. Fig. 4-22.

- a. Tighten the screws to the bottom, then back-up just enough to allow smooth, easy rotation of the housing in the event that the shoulder of the screws should contact the sides of the long slot in 2nd lens slide housing.

5.2 MIDDLE AND OUTER HELICOID TO INNER HELICOID

- a) Lubricate the helicoid threads of the inner, middle and outer helicoids as instructed in Section 4.5e and 4.5f.
- b) Assemble the outer helicoid to the middle helicoid bottoming the outer helicoid on its threads. If helicoid guides were removed, reinstall them making sure that the tips of the guides point to the front of the lens. **DO NOT FULLY TIGHTEN THE SCREWS**, leave them loose to allow the guides to float. Fig. 5-1.

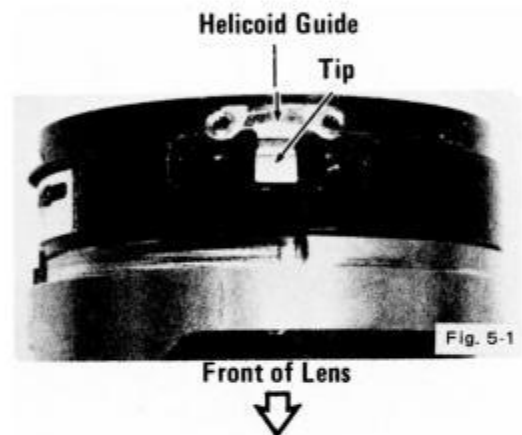

- c) Using Tool No. 3650537 as shown, place a scribe or reference line 9mm (.354") from the near focus limit of the infinity stop cutout of middle helicoid. Fig. 5-2. (Width of the tool is 9mm.)
- d) Unscrew outer helicoid until a distance of 0.25mm (.010") to 0.75mm (0.028") [usually about 0.5mm (.020") is right] is opened between the middle and outer helicoids and the edge of the infinity stop plate recess aligns with the scribe mark on the middle helicoid. Fig. 5-2.

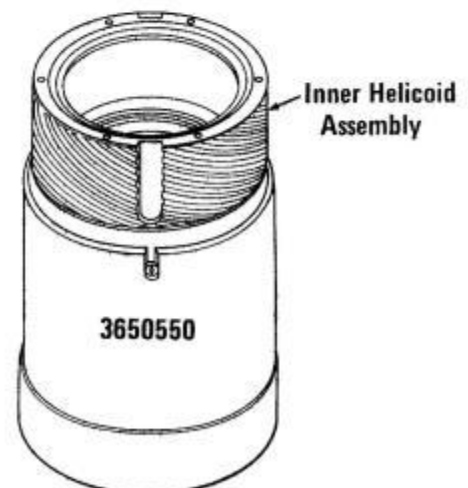
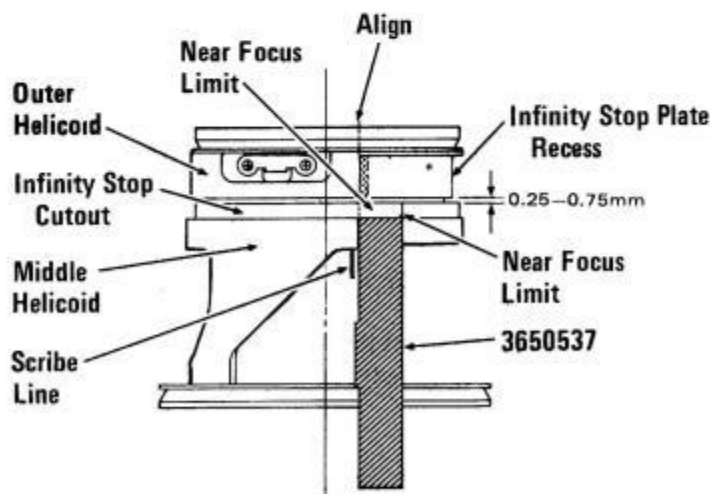

FIG. 5-2

FIG. 5-3

5.2

- e) Place the inner helicoid assembly on Tool No. 3650550 as shown in Fig. 5-3. Hold the outer and middle helicoids so that the alignment in 5.2d does not change. Set the middle helicoid down over the tool so that the center of the helicoid guides align with the holes in the helicoid nearest the helicoid guide slots as shown in Fig. 5-4.

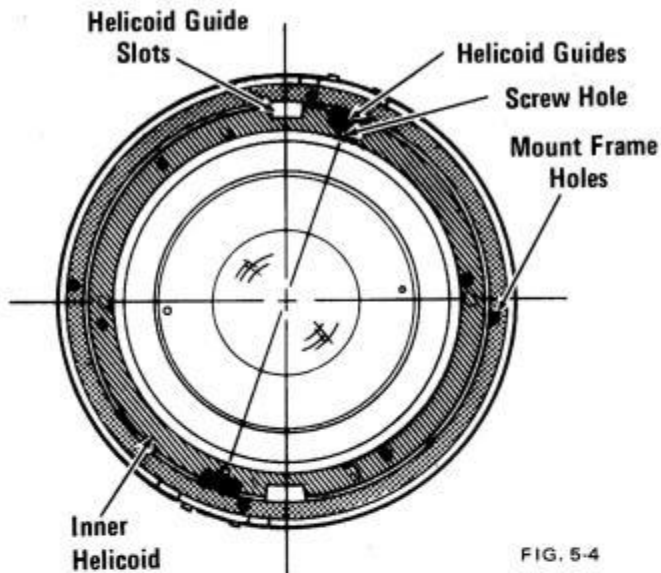

FIG. 5-4

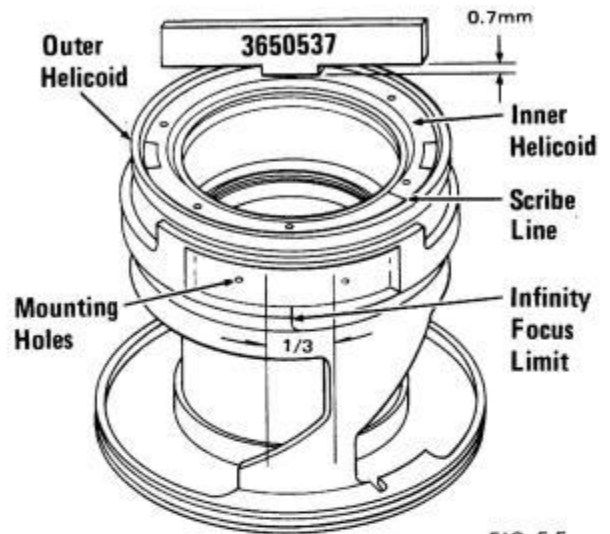

FIG. 5-5

- f) Mesh the helicoids at this point; rotate middle helicoid until helicoid guides just touch the inner helicoid. Rotate the outer helicoid to align the helicoid guides with the guide slots, while holding them in alignment, rotate the middle helicoid counter-clockwise until the guides enter the guide slots.
- g) If helicoid guides were left loose in 5.2a, rotate the helicoids back and forth and adjust the positions of the helicoid guides to provide for minimum axial play and smooth operation. Seal and tighten the helicoid guide mounting screws.
- h) Check for correct mesh of the helicoids by placing Tool No. 3650537 across the edge of the outer helicoid as shown in Fig. 5-5. Move the inner helicoid to contact the .7mm (.028") tip of the tool. With the helicoids set to this position, the infinity end of the infinity stop cutout should fall within the middle one-third of the distance between the infinity stop plate mounting holes.

NOTE: If the end of the infinity stop cutout does not meet the test described above, the helicoids were meshed one helicoid thread out of the correct position. Disengage the helicoids and repeat Instruction 5.2e, positioning the screw holes to one side or the other of the center of the helicoid guides.

- i) Install the infinity stop plate. Set the depth of the inner helicoid 0.7mm (.028") below the outer helicoid, then slide the tip of the infinity stop plate against the cutout. Seal the threads of the screws with thread sealant and tighten them.

5.3 BRIDGE RING

- a) Assemble bridge ring (25) to inner helicoid assembly by passing it through the slots in the outer ring of the middle helicoid. Fig. 4-9.
- b) Position bridge ring so that the holes in the bridge ring arms align with holes in the top of roller shafts (39). Apply thread sealant to the screws (2) and seat them firmly in the roller shafts making sure that the ring is square with the helicoid. Fig. 4-8.
- c) Rotate middle helicoid to infinity position; then push bridge ring (25) to the rear of the lens until it stops.

5.4 CONTROL HOUSING

5.4.1 INDEX RING

- a) With the helicoids set as instructed in 5.3c, slide index ring (291) onto the rear of the helicoid so that the near focus index line approximately aligns with the tip of the infinity stop plate. Fig. 5-6.

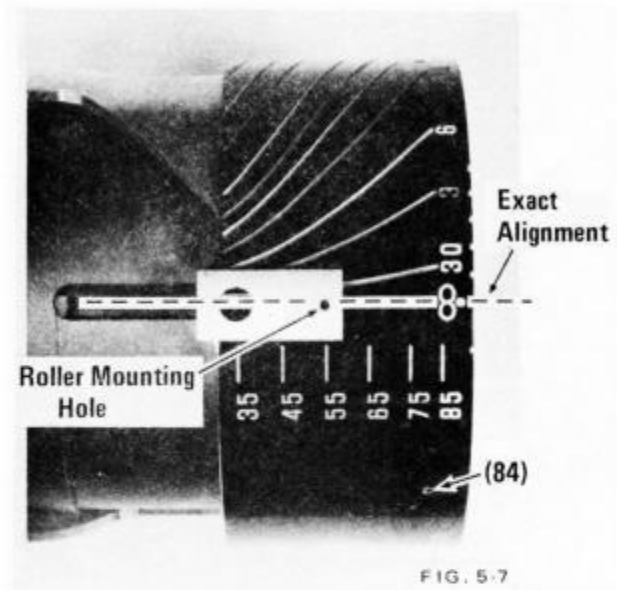
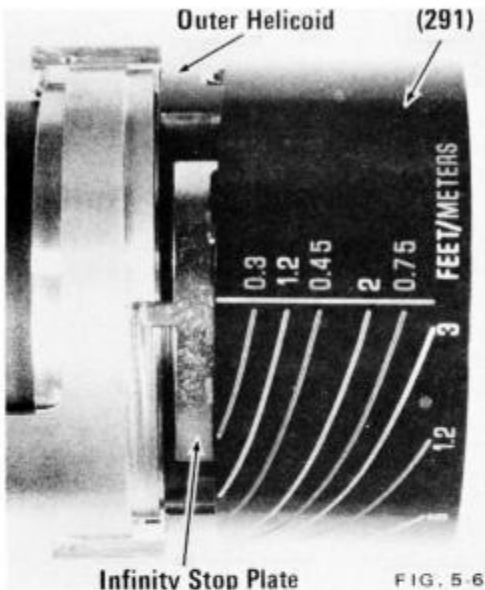

- b) Push the index ring fully on to the helicoid; then rotate the index ring until the infinity index line exactly aligns with the roller mounting hole in the bridge ring. Seal and tighten three setscrews (84), clamping the index ring to the outer helicoid. Fig. 5-7.

5.4.2 CAM RING

- a) Slide cam ring (23) onto the lens from the rear. Align the index dot approximately with the infinity index line of the index ring. Fig. 5-8.

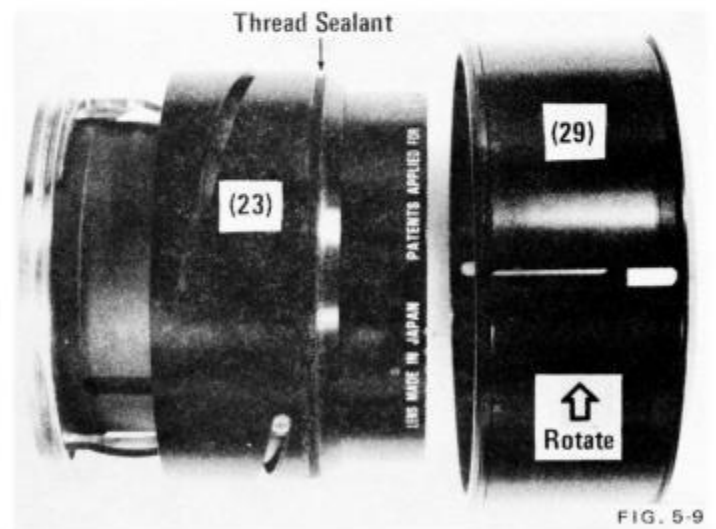
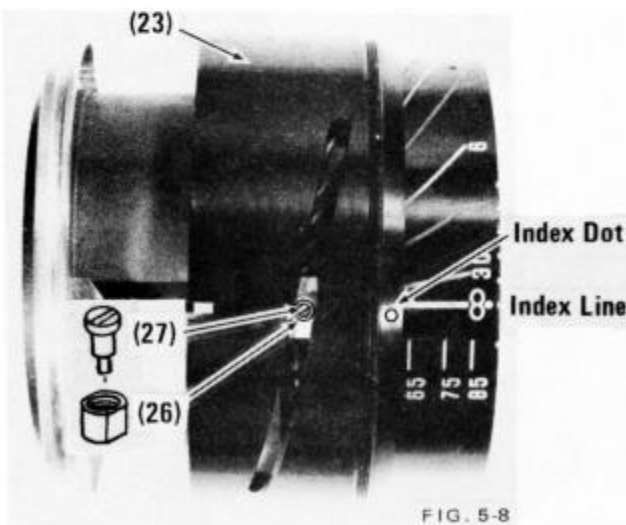

- b) Install a roller (26) through the cam slot and over the mounting hole in the bridge ring. Make sure that the counterbored side is outward.
- c) Install roller shaft (27) through the roller, sealing the threads with thread sealant. Do the same on the other side of the lens. Fig. 5-8.

5.4.3 CONTROL RING

- a) Place thread sealant on the threads of the cam ring (23), then thread control ring (29) onto the cam ring from the rear; tighten the control ring firmly. Fig. 5-9.

5.4.4 INNER FOCUSING RING

- a) Assemble hood ring (12) to inner focusing ring (13). Fig. 5-10.
- b) Slide inner focusing ring over middle helicoid and between the control ring and the cam ring until the hood ring stops against the middle helicoid. Rotate hood ring-inner focusing ring until a roller shaft hole aligns with a long slot in the control ring. Fig. 5-10.

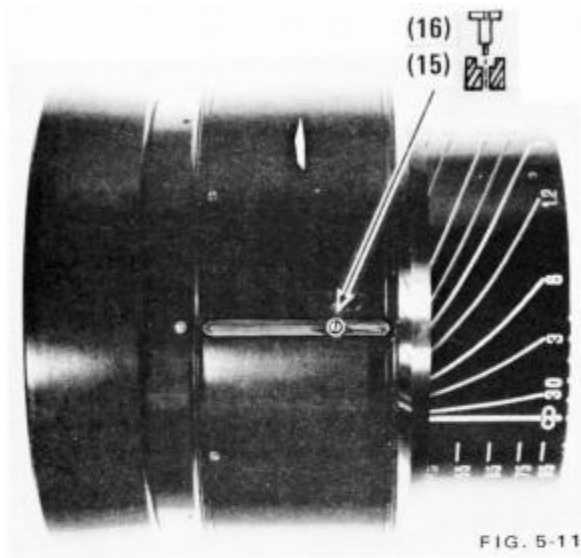
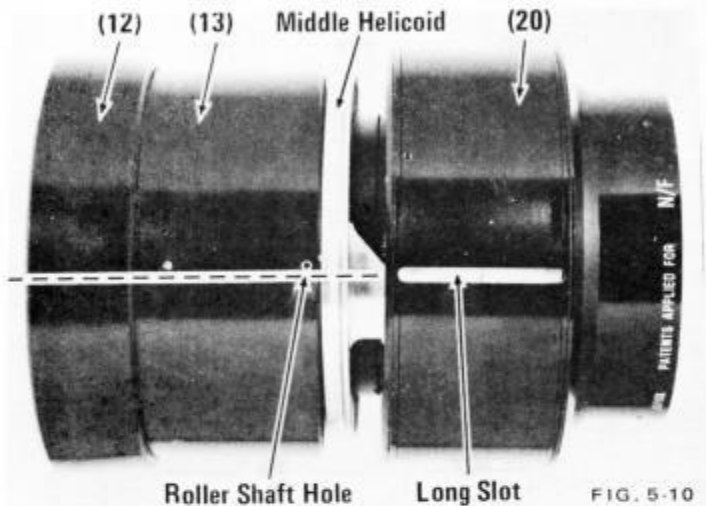

- c) Install a roller (15) in the slot over the roller shaft mounting hole; making sure that the counterbored end is outward. Place thread sealant on the threads of roller shaft (16) and install it through the roller and into its mounting hole. Do the same on the other side of the lens. Fig. 5-11.
- d) Adjust the position of the focus index dot on the control ring as follows:
1. Rotate the middle helicoid against the infinity stop. Fig. 5-12.
 2. HOLD middle helicoid against infinity stop; then rotate control collar to align the index dot with the infinity index line. Fig. 5-13.

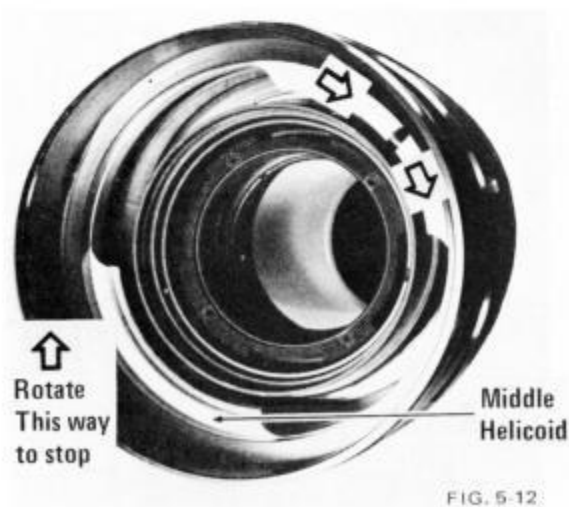

FIG. 5-12

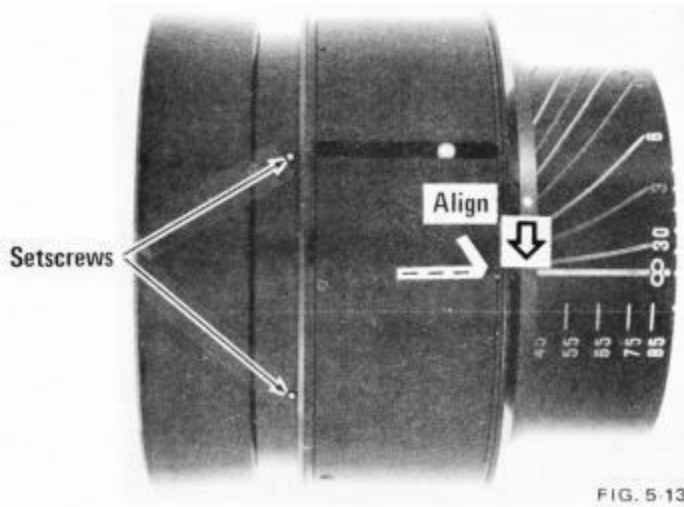

FIG. 5-13

3. Seal and tighten six setscrews securing the inner focus ring to the middle helicoid. Fig. 5-13.
- e) Remove hood ring and set aside. Final installation of this part will be made when re-installing the first lens group.
- f) Replace grip (19). Fig. 4-2.

6.0 CENTERING OF OPTICAL COMPONENTS

The performance of the lens is adversely affected if any of the optical components is not properly centered. The centering microscope and the tools supplied with it are to be used when centering optics.

The parts of the microscope are shown in Fig. 6-1 and are referred to in the text which follows. Referenced parts not shown in the illustrations will be found in the exploded drawings in Sec. 12.0.

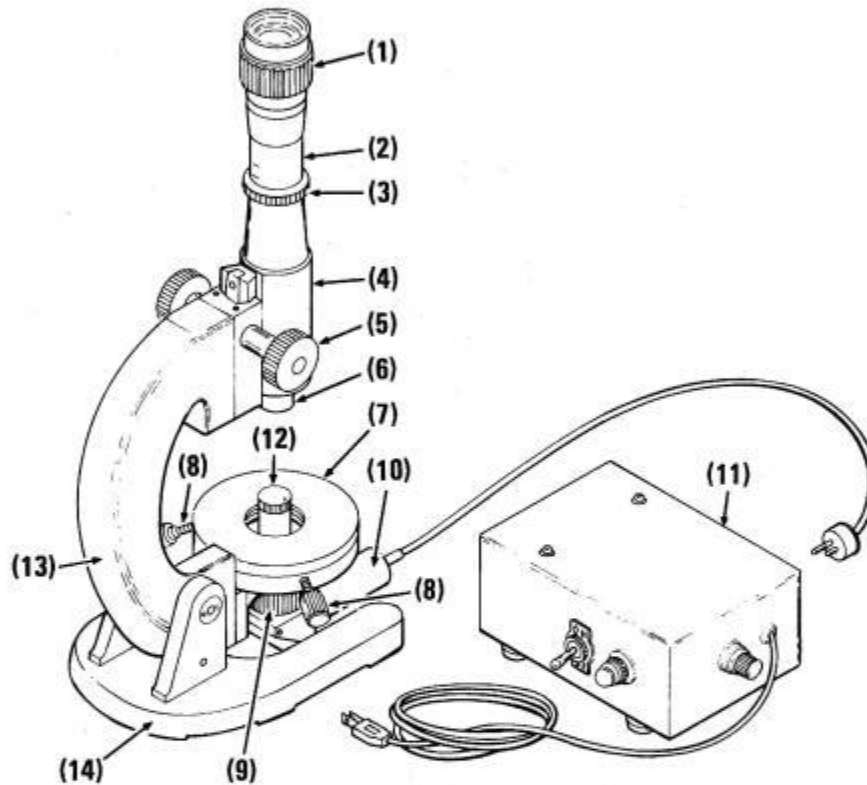

FIG. 6-1

Tool No. 3650528

- | | |
|---------------------------|--|
| 1. Eyepiece | 8. Stage Differential Adjusting Screws |
| 2. Microscope Tube | 9. Collimator Focusing Ring |
| 3. Clamp Ring | 10. Lamp Assembly |
| 4. Microscope Tube Holder | 11. Power Supply |
| 5. Focusing Knob | 12. Collimator |
| 6. Objective Lens | 13. Arm |
| 7. Stage | 14. Base |

The stage is threaded to accept tools 3650526, 3650533 and 3650534. Other tools are used with them to position the optical components for centering. The position of the stage (7) is adjustable about the axis of the microscope-collimator by turning the stage differential adjusting screws (8). In the instructions which follow, reference (8) will be referred to as "stage screws."

On the side of the microscope tube facing the user are several engraved lines. The line nearest the eyepiece is black, the next or second line is red. All the others are black. Fig. 6-2.

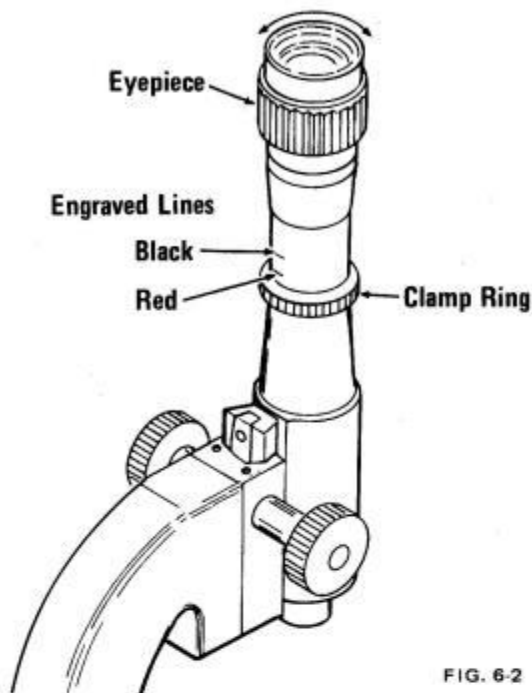

FIG. 6-2

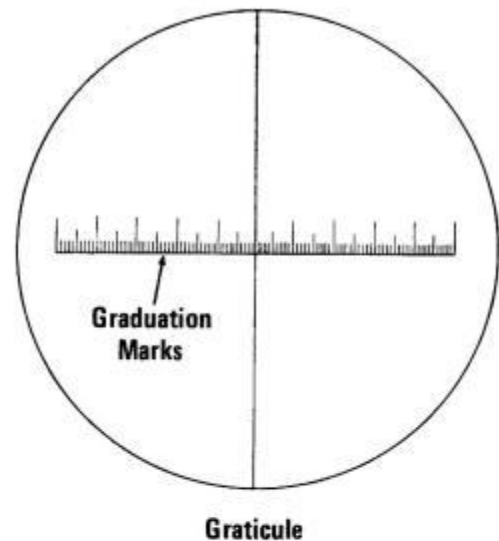

FIG. 6-3

When looking into the microscope through the eyepiece, with light reflected onto the front objective, a graticule will be seen. One of the cross lines has graduation marks. Fig. 6-3.

6.1 ADJUSTING THE EYEPIECE

- a) Adjust the eyepiece to your vision by turning the eyepiece clockwise or counterclockwise until the cross lines of the graticule are in sharp focus. Do not subsequently change the focus of the eyepiece unless it is turned or a different eye is used for viewing.

6.2 ADJUSTMENT OF COLLIMATOR

- a) Loosen clamp ring (3), push microscope tube (2) to the bottom of its travel. Fig. 6-1.

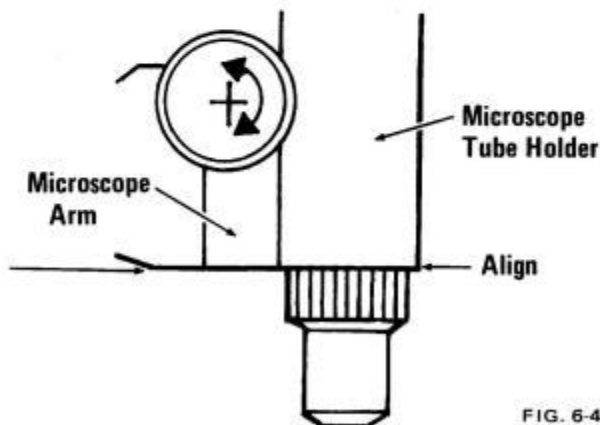

FIG. 6-4

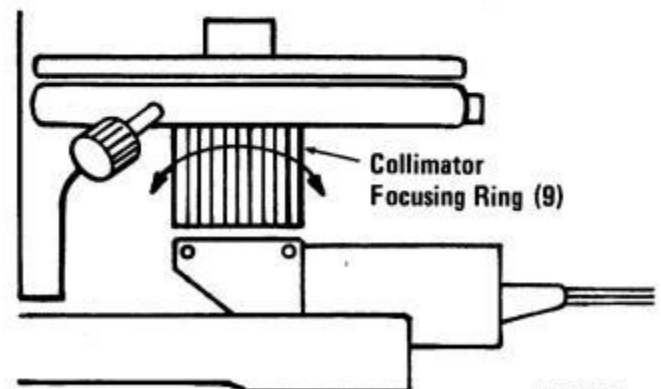

FIG. 6-5

- b) Rotate focus knob to align edge of microscope tube holder with edge of microscope arm. Fig. 6-4.
- c) Turn on the collimator lamp (switch on power supply) and adjust the collimator by rotating the collimator focusing ring (9, Fig. 6-5) until the green colored cross lines come into sharp focus.

CAUTION: The collimator cross lines will come into, and go out of focus very rapidly. Rotate the focusing ring slowly. Fig. 6-5.

6.3 CENTERING PROCEDURE (GENERAL)

After determining decentration, proceed as follows:

- a) Remove one-half of decentration by positioning lens group or element in the desired direction.
- b) Using stage screws, move collimator cross lines to center them under the eyepiece cross lines.
- c) Rotate lens or lens group in the holding tool to determine the remaining error.
- d) Repeat Instruction a) through c) until centering is within tolerance.
- e) Tighten the retaining ring to secure the optic.

6.4 CENTERING FIRST LENS GROUP

Assemble the tools, as shown in Fig. 6-6, to the microscope stage.

- a) Align the edge of microscope tube holder with the edge of the microscope arm. Fig. 6-4.
- b) Set microscope tube to the bottom of its travel; tighten clamp ring.
- c) Remove any focus spacers (11) from 1st lens group housing (3); place first lens group in holding tool 3650523.
- d) While looking into the microscope, turn focusing ring of collimator until cross lines of collimator and graticule are both in focus.
- e) While looking into the microscope, use stage screws to move collimator cross lines near the graticule cross lines. Rotate the lens group slowly in either direction. The collimator cross lines will appear to travel in the same direction as the lens is rotated. That is, if the lens group is rotated in a clockwise direction, the cross lines will travel the same direction. Fig. 6-7.

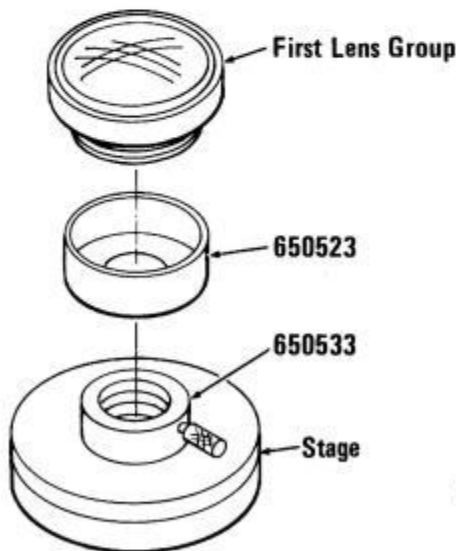
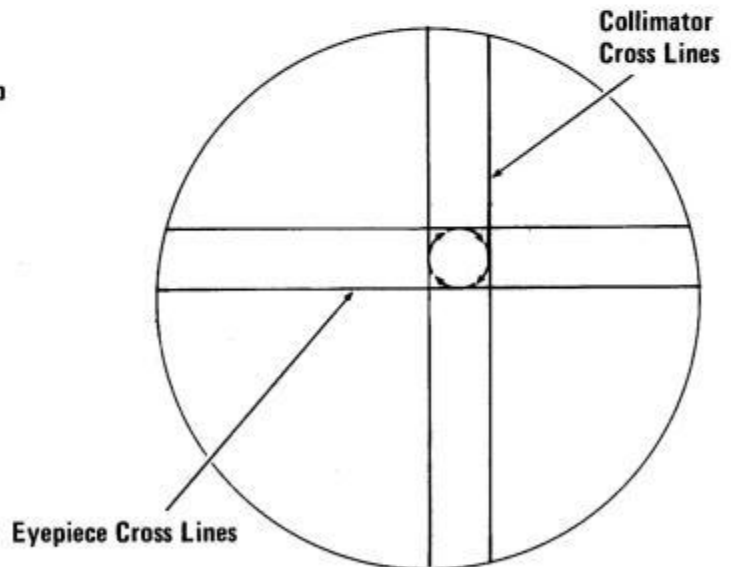

FIG. 6-6



(graduations omitted for clarity)

FIG. 6-7

- f) Adjust centering by loosening and tightening the name ring (4) to force the strong curved front surface of first lens element (5) to center against the name ring.
- g) Adjust the centering to within one graduation of the graticule.

6.4.1 REPLACEMENT OF LENS ELEMENT OR REMOVAL OF DUST

a) First and Second Lens Elements

1. Remove name ring
2. Remove dust or replace lens element(s).
3. Recenter following instruction 6.4f.

b) Second and Third Lens Elements

1. Remove third lens element retaining ring (10).
2. Replace element or remove dust, etc.; replace lens element in housing.
3. Tighten retainer ring evenly so that the curved surface of the lens element is held firmly against the lens group housing.

6.5 CENTERING OF SECOND LENS GROUP IN LENS GROUP HOUSING

- a) Assemble the tools as shown in Fig. 6-8 to the microscope stage.
- b) Align the edge of microscope tube holder with the edge of microscope arm. Fig. 6-4.
- c) Loosen retainer ring (35) then place second lens group and housing in Tool No. 3650524.
- d) Focus collimator cross lines.
- e) While looking into the microscope, use stage screws to move collimator cross lines under eyepiece cross lines.
- f) Adjust centering to within one graduation.
- g) Tighten retainer ring to secure the lens group in the housing.

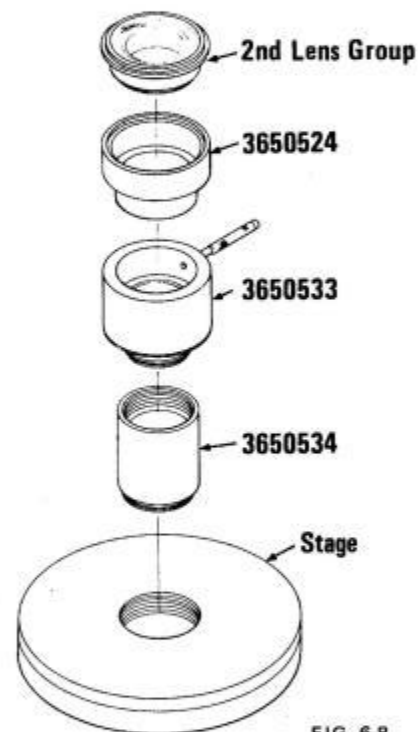

FIG. 6-8

6.6 CENTERING OF THIRD LENS GROUP IN LENS GROUP HOUSING

- a) Assemble the tools, as shown in Fig. 6-9, to the microscope stage.
- b) Align the edge of microscope tube holder with the edge of the microscope arm. Fig. 6-4.
- c) Set microscope tube to bottom of its travel; tighten clamp ring.
- d) Place third lens group and housing with the deep concave side of the optic facing the collimator in Tool No. 3650525.
- e) Focus collimator cross lines.
- f) While looking into the microscope, use stage screws to move collimator cross lines under graticule cross lines.

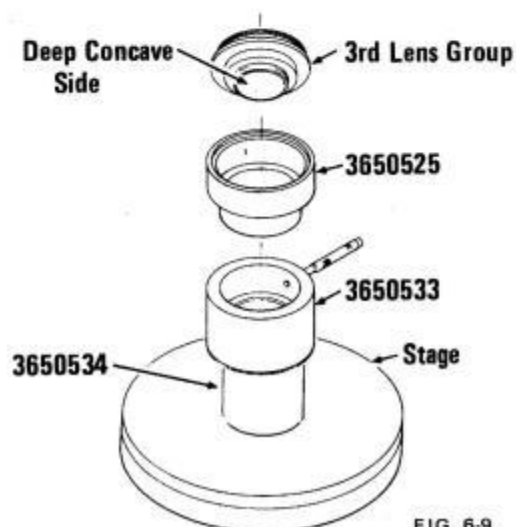

FIG. 6-9

6.6

- g) By moving the lens group in its housing, adjust the centering to within one graduation.
- h) Tighten retainer ring to secure the lens group in the housing.

6.7 CENTERING OF FOURTH LENS IN DIAPHRAGM HOUSING

Positioning ring (58) and lens housing ring (59) are eccentric rings as shown in Fig. 6-10A and B.

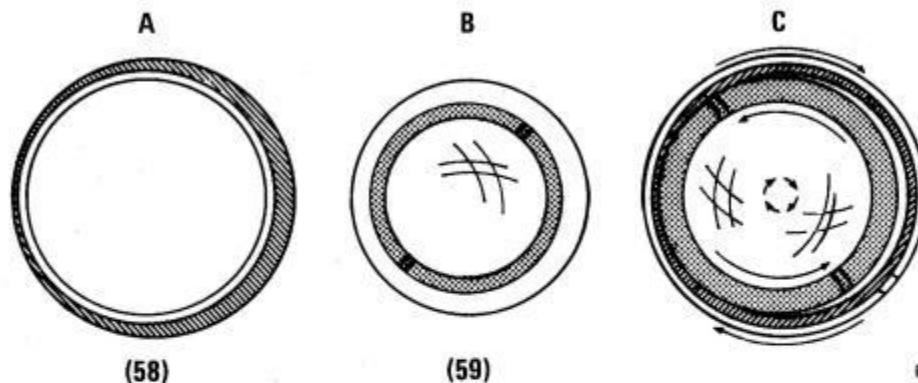

FIG. 6-10

By rotating either, the positioning ring, or the housing ring, the center of the lens will travel in a small circular manner as in Fig. 6-10C. Differential rotation of the rings allows the lens to be exactly centered in the diaphragm housing.

- a) Remove fifth lens group and any spacers from the diaphragm assembly.
- b) Assemble Tool No. 3650526 to the stage, screwing it to the bottom of the threads and against the shoulder of the tool. Fig. 6-11.
- c) Align the edge of microscope tube with edge of microscope arm. Fig. 6-4.
- d) Set the microscope tube so that the red line (second line from top) on the tube aligns with the edge of the clamp ring; tighten clamp ring.
- e) Place diaphragm housing assembly, with 4th lens installed, down over Tool No. 3650526 so that it rests on the tool and rotates freely.
- f) Focus collimator cross lines.
- g) While looking into the microscope, use stage screws to move collimator cross lines under the graticule cross lines.
- h) Observe centering. If centering is correct do not disturb the lens. If not, proceed as follows:

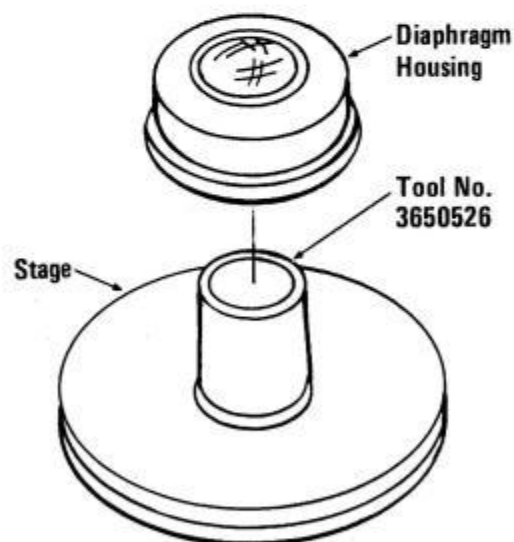

FIG. 6-11

1. Loosen locking ring (55) and center the lens by rotating positioning ring (58) or lens housing ring (59) or both as described, to cent the lens. Fig. 6-10C.
2. Adjust the centering to within two graduations. When the lens is properly centered, tighten locking ring securing the lens in position.

6.8 CENTERING OF FIFTH LENS GROUP

The following procedure will be principally used when it is necessary to replace the 12th lens (191) or to remove dust from the rear lens group.

The 9th and 10th lens elements (510) (doublet) is shouldered and is retained by a retainer ring (75). The retainer ring fits around the shoulder and assures centering when assembled.

- a) Assemble the tools, as shown in Fig. 6-12, to the microscope stage.
- b) Align the edge of microscope tube with the edge of the microscope arm. Fig. 6-4.
- c) Set microscope to bottom of its travel; tighten clamp ring.
- d) Place fifth lens group (with retainer ring for rear element loosened) in Tool No. 3650527.
- e) Focus collimator cross lines.
- f) While looking into the microscope, use stage screws to move the collimator cross lines under graticule cross lines.
- g) Observe the centering. Alternately tighten and loosen retainer ring, forcing it to center the lens in the housing. Tapping the housing lightly will aid in centering.
- h) Adjust centering to within one graduation.

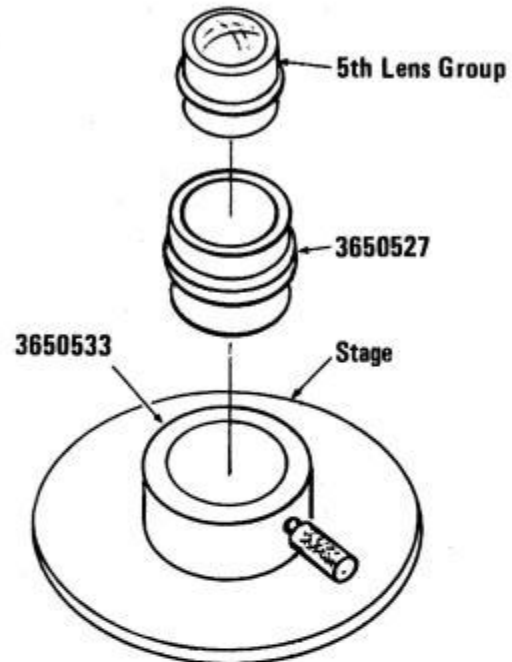

FIG. 6-12

6.9 CENTERING OF SECOND LENS GROUP IN THE LENS BARREL (Refer to exploded view drawings)

The proper centering of the second lens group in its slide housing is critical to the optical performance of the lens. The entire service operation will be nullified if the procedure which follows is not accurately accomplished. Proceed as follows:

- a) Remove fifth lens group from lens. Use Tool No. 3650522.
- b) Remove first lens group and hood ring.
- c) Assemble Tool No. 3650526 to the microscope stage, screwing it to the bottom of the threads and against the shoulder of the tool. Fig. 6-13.
- d) Make sure that both front and rear surfaces of third lens group are clean and that the lens group is firmly seated in its slide housing.
- e) Install second lens group in its slide housing using Tool No. 3650520.
- f) Install, but do not tighten, four screws (36) which retain the lens group in the slide housing. Fig. 6-13.
- g) Set the lens to the 85mm focal length position, focus index dot to infinity index line.
- h) Place Tool No. 3650519 down in the lens so that it fits around the ring of the second lens group, and the pads on the adjusting screws just touch the sides of the inner focusing ring. Adjust the position of the tool on the lens so that a long screwdriver will reach into the retaining screws (36). Fig. 6-13.

6.9

- i) Raise microscope tube to the top of its travel; place lens and tool down over Tool No. 3650526 seating it on the tool. Check for free rotation of the lens on the tool.
- j) Set the microscope so that the red line (second line from top) on the tube aligns with the edge of the clamp ring; tighten clamp ring.
- k) Align edge of microscope holder with the edge of the microscope arm. Fig. 6-4.

l) Look into microscope; focus collimator cross lines.
NOTE: Because of magnification, the collimator cross lines will appear wider and somewhat indistinct when compared to centering the individual optical groups.

m) While looking into the microscope, use stage screws to move collimator cross lines into the field of view of the microscope.

n) Use adjusting screws on Tool No. 3650519 to move collimator cross lines one-half the distance to the graticule cross lines. (As one screw is tightened to move the tool, loosen the opposite screw an equal amount.)

o) Use stage screws to move collimator cross lines under graticule cross lines. If unable to move collimator cross lines in the direction of eyepiece cross lines, then use tool adjusting screws to move collimator lines further.

p) When able to move collimator cross lines within five graduation marks of graticule cross lines, center collimator cross lines under eyepiece cross lines using stage screws.

q) Rotate the lens slowly and observe centering.

r) Use adjusting screws on the tool to remove one-half of the error in centering.

s) Move collimator cross lines under graticule cross lines using stage screws.

t) Repeat Instructions q), r), and s) until second lens group is centered within two graduations.

u) Tighten four screws securing second lens group.

v) Remove centering tool 3650519.

w) Paint the heads of the screws with flat black paint.

x) Install fifth lens group.

y) Assemble first lens group and hood ring to the lens.

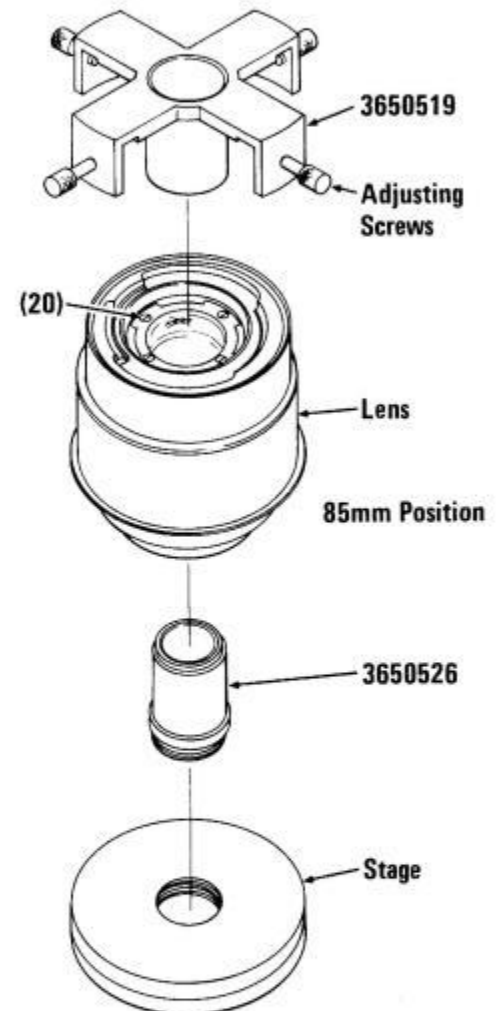

FIG. 6-13

7.0 FOCUS ADJUSTMENT

7.1 TEST EQUIPMENT

- a) Auto-Collimator — It is strongly recommended that an auto-collimator be used for focusing, either with a test fixture to simulate flange focus distance or with a properly adjusted camera body.
- b) Ground Glass — A ground glass should be used only if no auto-collimator is available, in which case the following points should be considered:
 1. The camera flange focus distance must be correct.
 2. The ground glass should be shimmed about 0.05mm from the guide rails.
 3. A high-power magnifier (20–50X) should be used to examine the image.
 4. An infinity collimator image is preferable to an infinity object viewed through the shop window.

7.2 DEFINITIONS

FOCUS SHORT — When rotating control ring to focus at infinity, focus index dot stops at the infinity stop before infinity focus is reached. That is, infinity focus of the lens is beyond the infinity mark of the index ring. Fig. 7-1.

FOCUS OVER — When rotating control ring to focus at infinity, infinity focus is reached before the focus index dot reaches the infinity index line. Fig. 7-2.

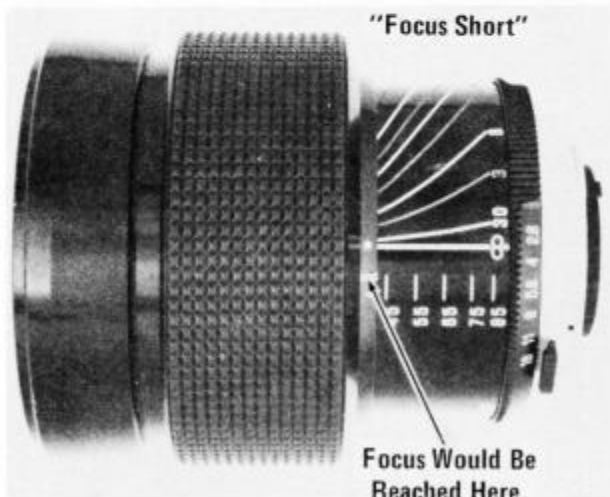

FIG. 7-1

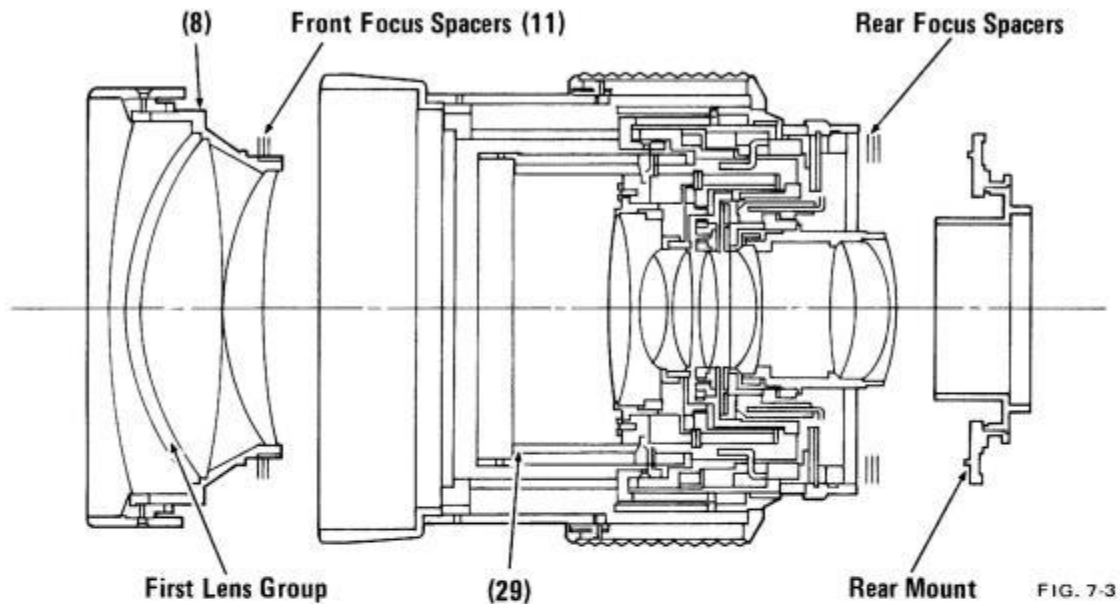

FIG. 7-2

7.3 FOCUS SPACERS

Front focus spacers (11) are supplied in thicknesses of 0.1, 0.15, 0.2 and 0.4mm. Fig. 7-3.

Rear focus spacers are supplied in thicknesses of 0.1, 0.15 and 0.2mm. (Consult parts list and exploded drawings for part numbers.) Fig. 7-3.



7.4 GENERAL FOCUSING PROCEDURE

- a) If first lens group was removed only to permit access to other parts of the lens, replace first lens group and front focus spacers as disassembled.
- b) If first lens group slide housing (29) was replaced in the repair procedure, place front focus spacers (11) between first lens group housing (8) and first lens group slide housing with an initial thickness of 0.6mm. Fig. 7-3.
- c) Use rear focus spacers as disassembled, or if a new rear mount was installed, place focus spacers between mount and mount frame with an initial thickness of 0.5mm.

7.4.1 35mm INFINITY FOCUS

- a) Set lens to 35mm focal length position, focus scale to infinity position.
- b) Observe infinity focus of the lens on infinity target.
- c) If 35mm infinity focus is "over," increase thickness of rear focus spacers.
- d) If infinity focus is "short," reduce thickness of rear focus spacers.

7.4.2 85mm INFINITY FOCUS

- a) Set lens to 85mm focal length position, focus scale to infinity position.
- b) Observe infinity focus of the lens on infinity target.
- c) If 85mm infinity focus is "over," increase thickness of front focus spacers.
- d) If 85mm infinity focus is "short," reduce thickness of front focus spacers.

7.4.3 FOCUS ADJUSTMENT CHECK

Repeat the steps for focusing the lens at the 35mm and the 85mm focal length positions to achieve optimum focus at both focal lengths.

CAUTION: Reducing or increasing thickness of focus spacers at either position may change the infinity focus at the opposite position.

8.0 CONTROL RING DRAG ADJUSTMENT

- a) Roll grip (19) back to expose drag adjustment screws (22) (two on each side of lens). Fig. 8-1.
- b) Adjust screws inward to increase drag, outward to decrease drag. Adjust drag to be 700–900 grams (24–32 oz) in either direction.
- c) Roll grip back into position on control ring.

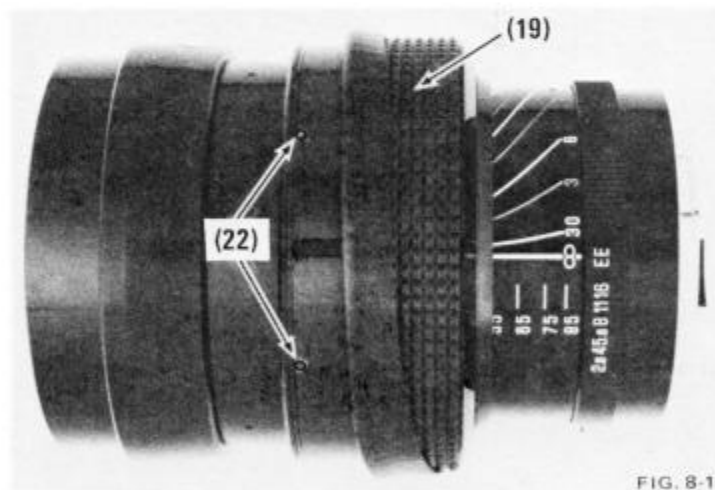

9.0 SPECIAL TOOLS

Three special tools are provided for use on lenses with Canon and Olympus Series mount lenses. The instructions which follow fully describe how to use them.

9.1 VIVITAR TOOL NO. 3650530 – CANON MOUNT

The automatic/manual aperture ring (186), and the aperture signal ring (170) are shown in Figures 9-1 and 9-2. They are mounted in ball bearing races in the Canon mount and extend through the sensing ring on the back of the mount. The rear projection on each ring is engaged by a lever in the camera. Exposure measurement information is relayed to the diaphragm of the lens through these rings.

Automatic/Manual Aperture Ring

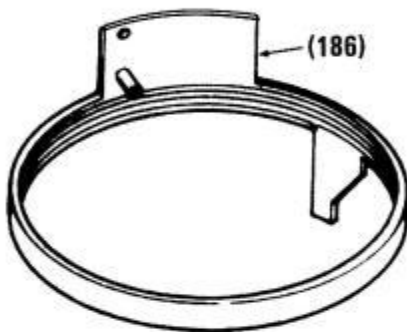

FIG. 9-1

Aperture Signal Ring

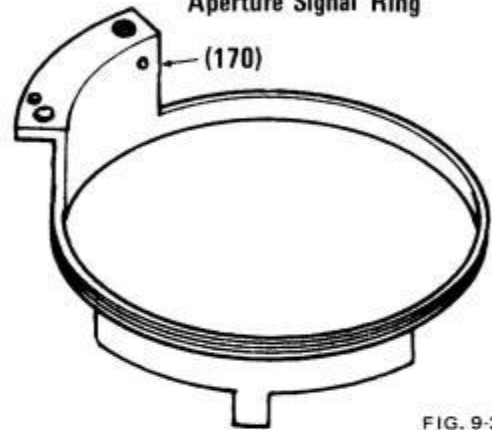

FIG. 9-2

The tool is used to position two stop plates (179) which limit the travel of the rings. Fig. 9-3.

Prepare the mount for use with the tool by removing retainer (171), diaphragm lever shaft (172) and diaphragm lever assembly (527). Fig. 9-3.

Place the mount on the tool in the same manner as installing a lens on the camera, then proceed as follows:

- For correct adjustment, the front projection on the aperture signal ring must rest against stop "A" of the tool. Fig. 9-4.
- For correct adjustment, the front projection of the automatic/manual aperture ring must rest against stop "B" of the tool. Fig. 9-4.

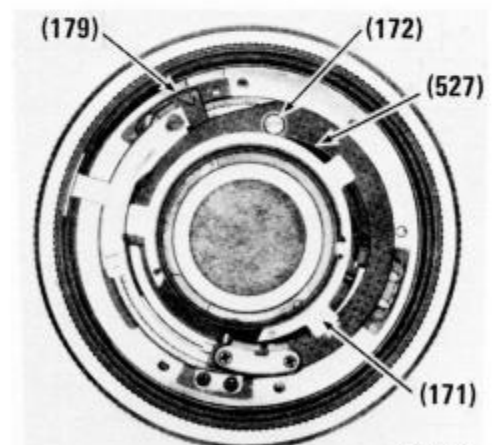
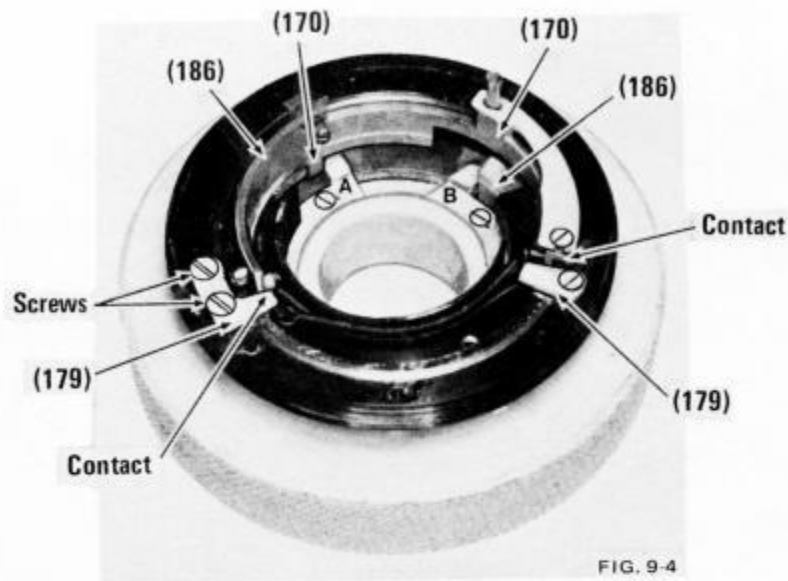

FIG. 9-3

- Adjust positions of stop plates (179) on the mount, so that they just make contact with the rear projections on the two rings when the front projections are against the stop plates of the tool as described in steps a) and b). Fig. 9-4.

CAUTION: Whenever the Canon mount is removed from a lens and particularly when a new mount is installed on a lens, perform this check on the positions of the stop plates and adjust them if necessary.



9.2 VIVITAR TOOL NO. 3650531 – CANON MOUNT

Tool No. 3650531 is used to confirm the f /stop positions of the diaphragm setting ring of the Canon Mount in the "Auto" mode of operation. Positions of the diaphragm and diaphragm setting ring are confirmed in the manual mode of operation so that when the lens is set in the "Auto" mode, correct diaphragm operation is assured.

The tool consists of two principle parts: A knurled outer ring with position tab and an inner ring with notch to engage the locating pin on the lens mount. Fig. 9-4.

Looking at the face (bottom) of the tool, there are three scribed lines on the inner ring. One line is scribed for the $f/2.8$ position, one line for the $f/5.6$ position, and the third for the $f/16$ position. Fig. 9-6.

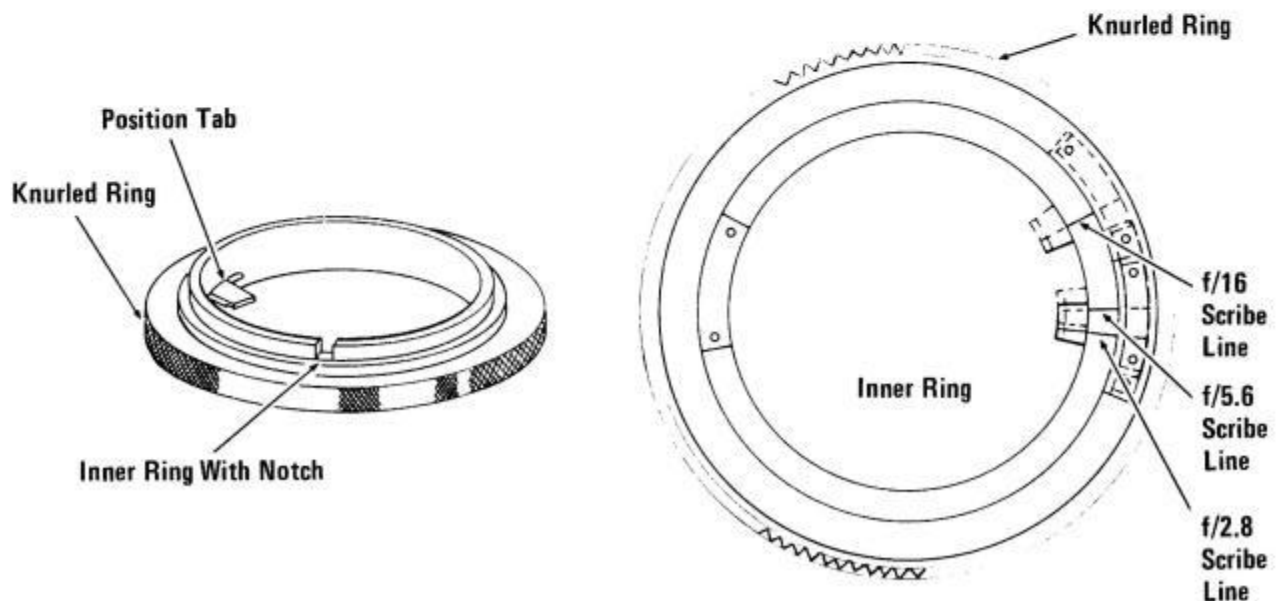

Fig. 9-5.

9.2 a) Prepare the Canon mount for use with the tool as follows:

1. Set automatic/manual aperture ring (186) to the manual position.
2. Viewing the mount from the rear, rotate locking ring (192) fully counterclockwise.
3. Set the aperture ring (160) to f/2.8. Fig. 9-7.

b) Place Tool No. 3650531 on Canon mount so that notch in tool fits down over locating pin of mount. Fig. 9-7.

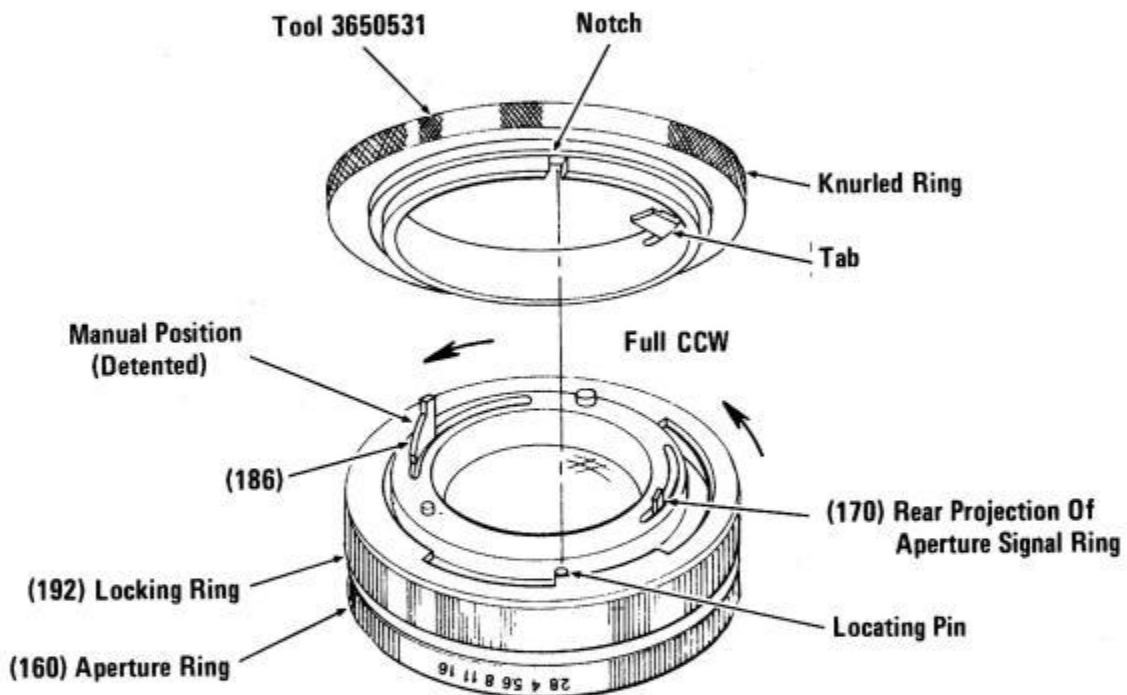

FIG. 9-7

- c) With the aperture ring of the lens set at f/2.8 and detented, rotate the knurled ring of the tool so that the scribe lines for the f/2.8 position align. The rear projection of the aperture signal ring should just touch the tab on the tool. Fig. 9-8A.
- d) Rotate the knurled ring of the tool of the f/5.6 position; align scribe marks. Rotate the aperture ring of the lens to f/5.6. The rear projection of the aperture signal ring should just touch the tab on the tool. Fig. 9-8B.
- e) Rotate the knurled ring of the tool to the f/16 position; align scribe marks. Rotate the aperture ring of the lens to f/16. The rear projection of the aperture signal ring should just touch the tab on the tool. Fig. 9-8C.

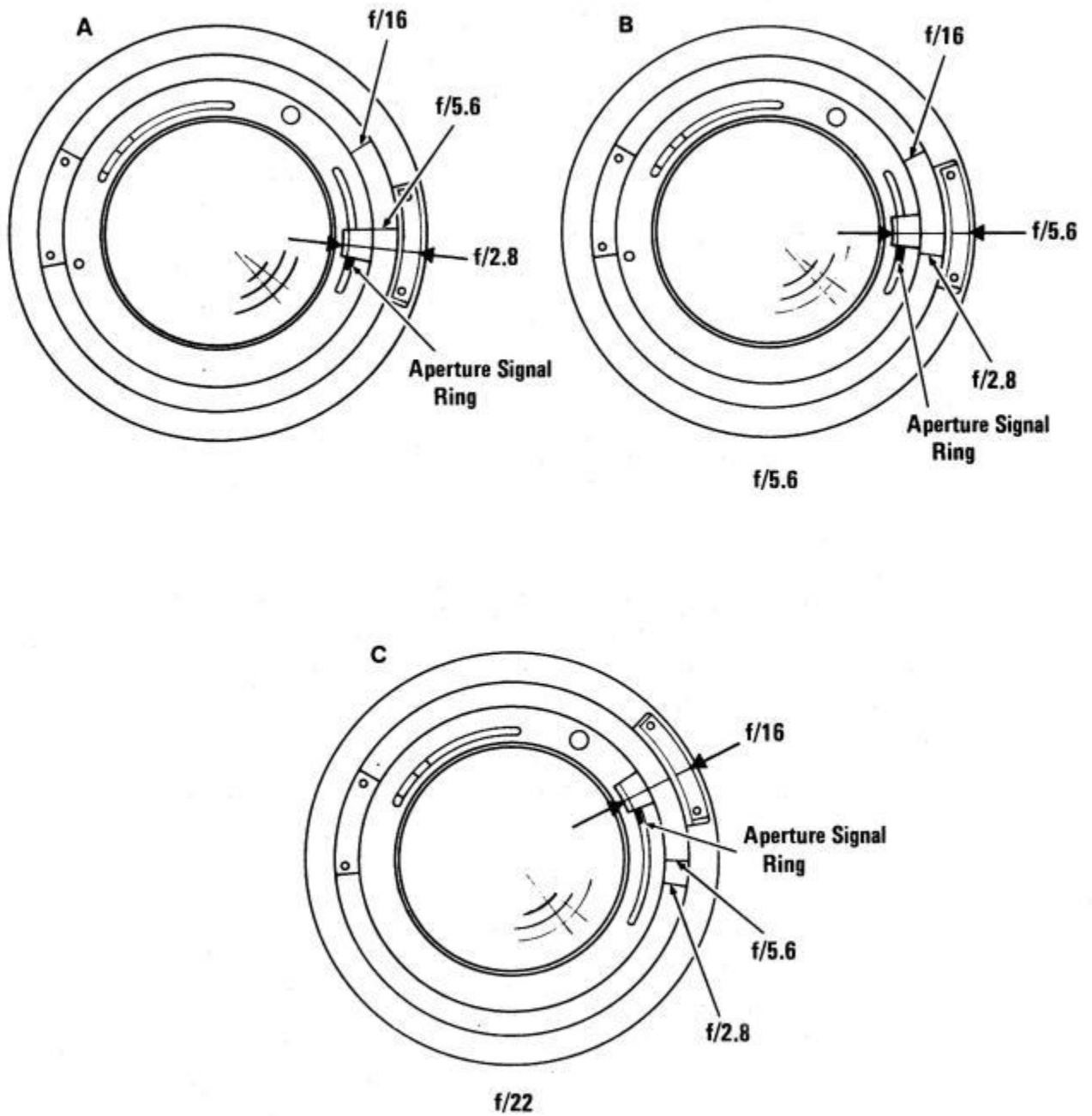

FIG. 9-8

9.3 VIVITAR TOOL NO. 3650532 – OLYMPUS OM SERIES MOUNT

Tool No. 3650532 is used to adjust the position and height of aperture coupling arm (225) so that aperture coupling of the lens to the camera is correct and the coupling arm does not protrude so deep into the camera as to cause a mirror lock-up malfunction.

Prepare the lens for use with the tool by removing the mount as instructed in Section 2.6 then proceed as follows:

- a) Set the aperture ring of the lens to any position between $f/2.8$ and $f/5.6$.
- b) With the lens positioned as shown in Fig. 9-9, set the tool down on the lens so that the aperture coupling arm enters the cutout of the tool and the positioning pins of the tool enter the mount screw holes.

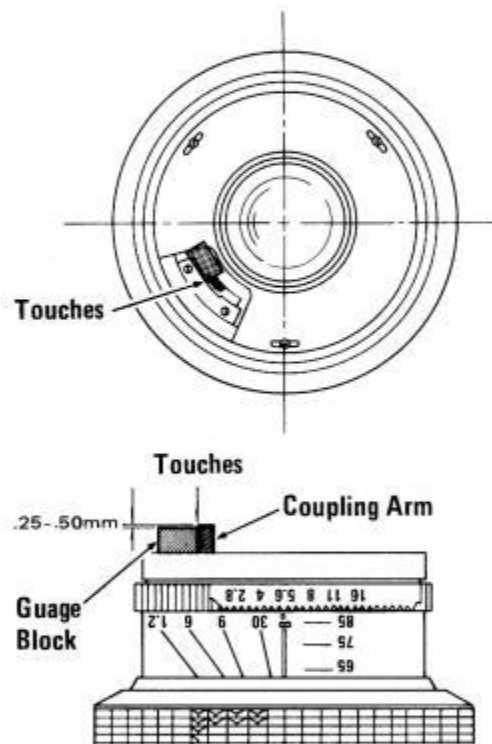
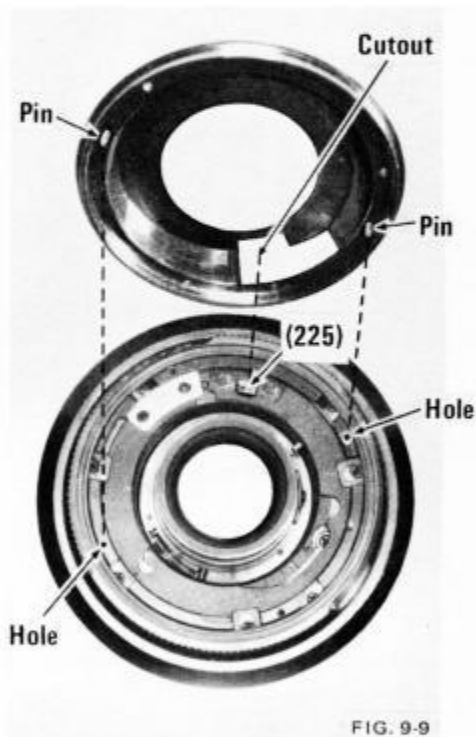

- c) Set the aperture ring to $f/5.6$. The coupling arm should just contact the face of the positioning block as the aperture ring detents into the $f/5.6$ position. Fig. 9-10.

- d) Height of coupling arm should be from 0.25mm (.010") to 0.50mm (.020") above the height of the gauge block.

9.3

e) If coupling arm does not contact gauge block, or height of arm is incorrect, proceed as follows:
(Refer to Fig. 9-11.)

1. Loosen screws (226); adjust the position of the coupling arm (225) until it will contact gauge properly.
2. Add or remove spacer shims (224) until proper height is obtained.

f) Reassemble mount to lens.

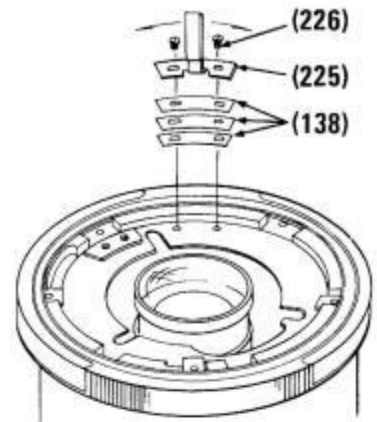

FIG. 9-11

10.0 REAR MOUNT ASSEMBLIES

Rear mount assemblies are shown in the following illustrations to assist in any necessary repairs to the mounts. The various parts are referenced corresponding to the exploded drawings in Section 12.0.

10.1 UNIVERSAL SERIES MOUNT

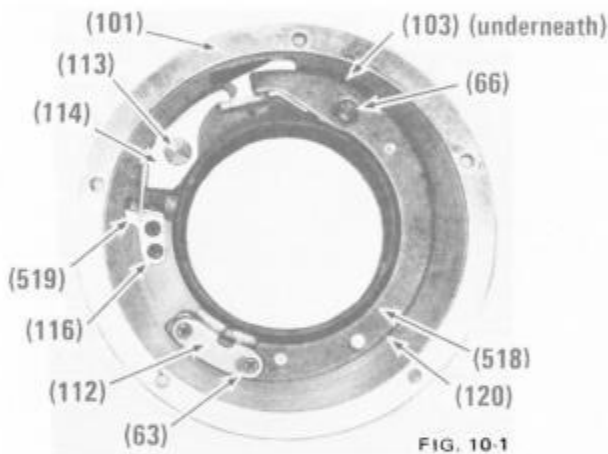

FIG. 10-1

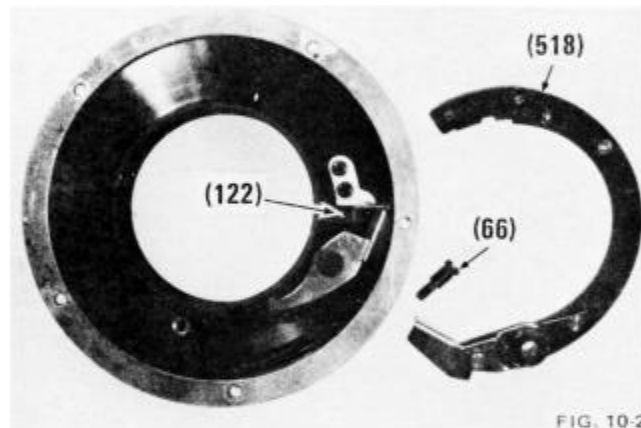

FIG. 10-2

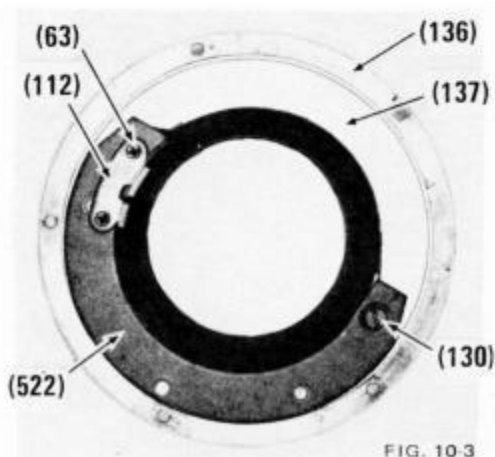

FIG. 10-3

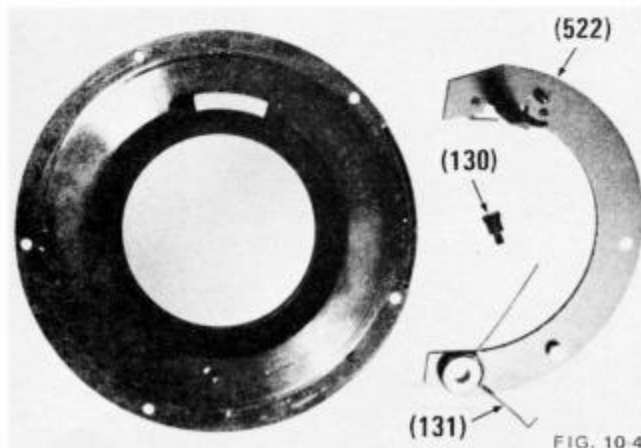
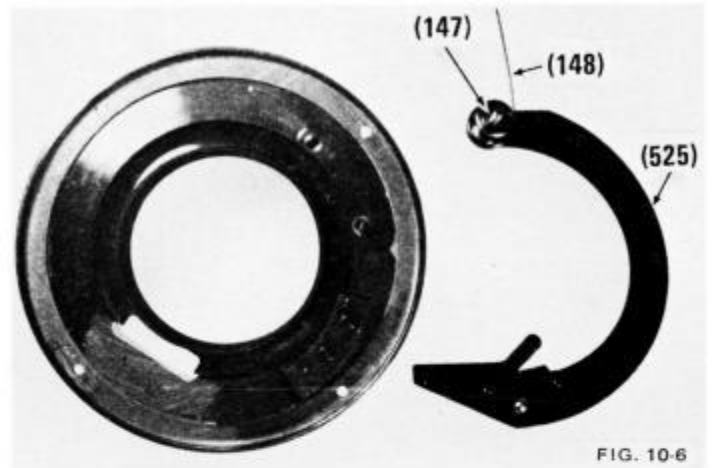
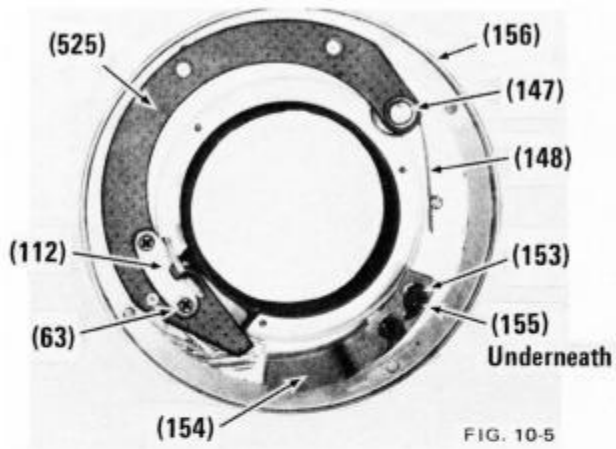
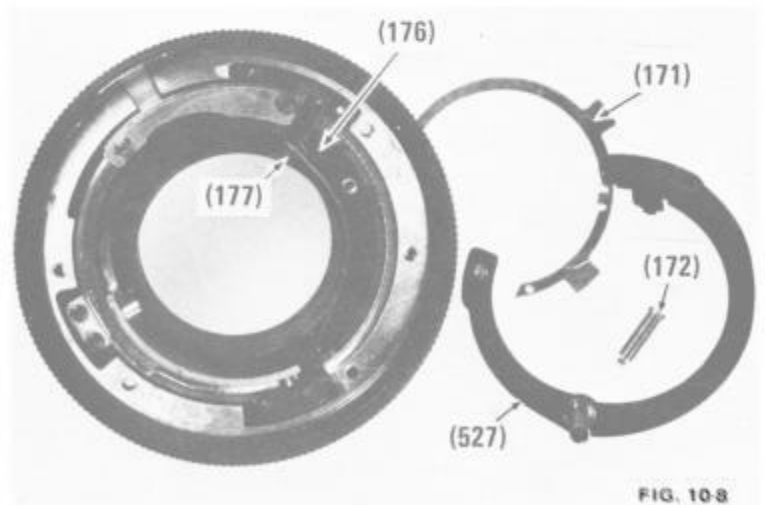
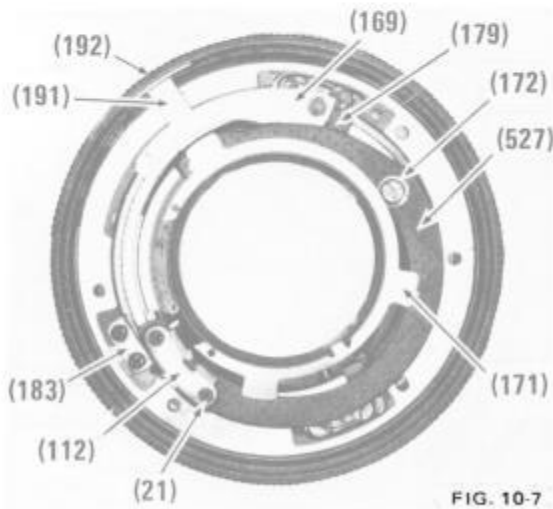

FIG. 10-4

10.3 MINOLTA SR/SRT SERIES MOUNT



10.4 CANON FT/FD SERIES MOUNT



10.5 KONICA MOUNT

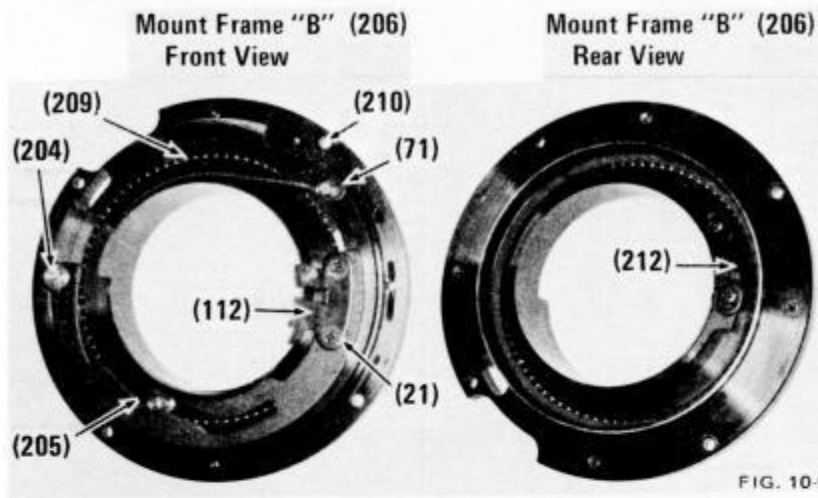

NOTE: In the Konica mount there are two main assemblies; mount frame (B) (206) and Konica mount (215). Mount frame (B) contains all moving parts, while the Konica mount and the f/stop setting ring attach the lens to the camera. Do not attempt to replace any parts except those referenced above.

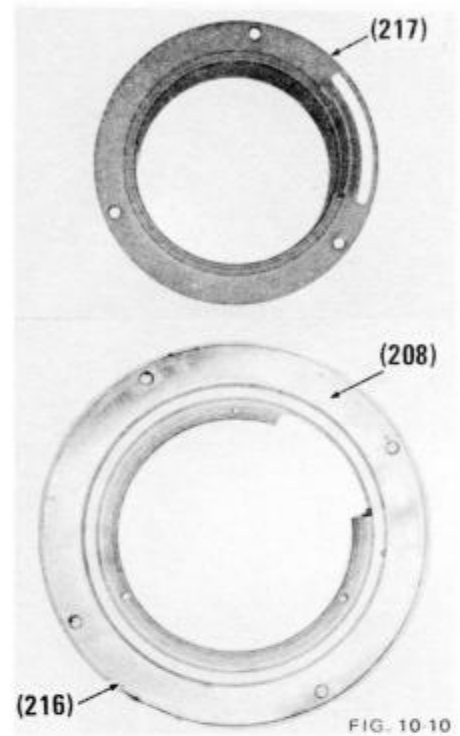

10.6 OLYMPUS-OM SERIES MOUNT

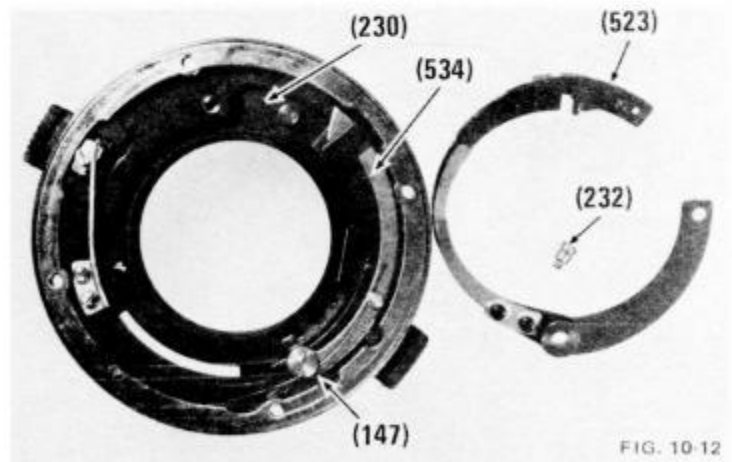
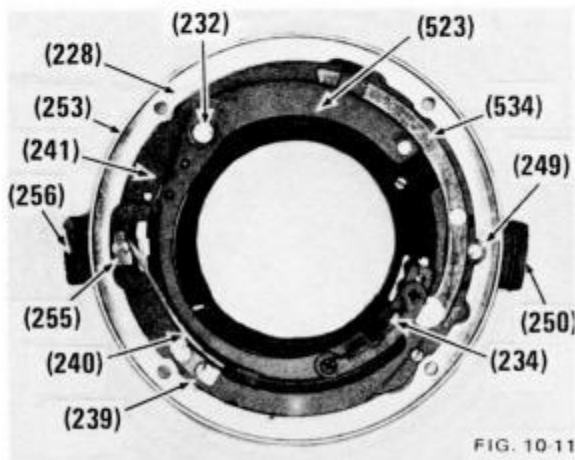

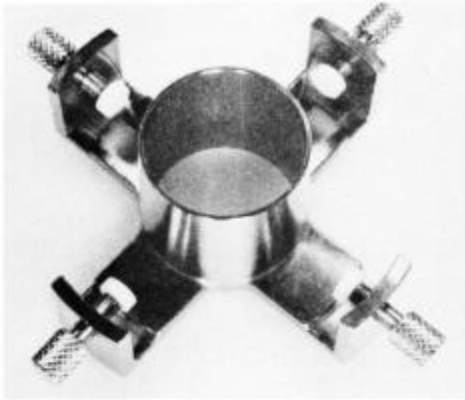
VIVITAR TOOLS FOR SERIES 1 35-85 VARIFOCAL LENS

3650519 Use to position 2nd Lens Group when centering in lens barrel.

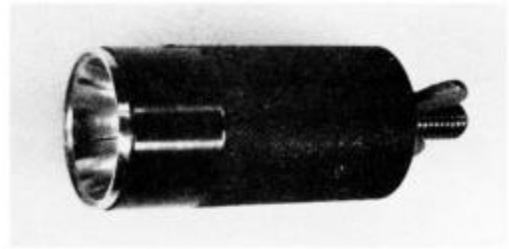

3650520 Use to remove/replace 2nd Lens Group in lens barrel.

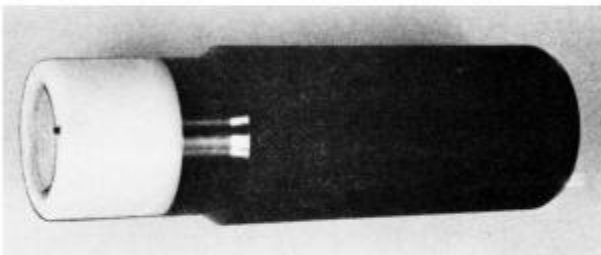

3650521 Use to remove/replace 3rd Lens Group in lens barrel.

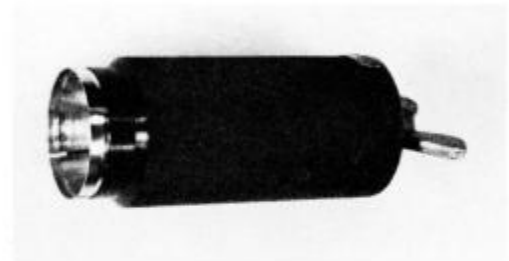

3650522 Use to remove/replace 5th Lens Group.



3650523 Use to hold 1st Lens Group in Tool No. 3650533 and centering microscope.



3650524 Use to hold 2nd Lens Group frame when centering 2nd Lens Group in frame.

3650525 Use to hold 3rd Lens Group frame when centering in frame. Use together with 3650533.



VIVITAR TOOLS FOR SERIES 1 35-85 VARIFOCAL LENS



3650526 Use to hold diaphragm housing when centering 4th Lens element and to hold lens barrel when centering 2nd Lens Group in lens barrel.

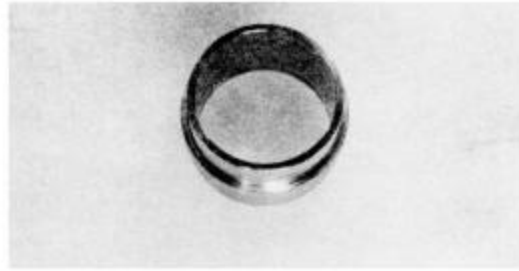

3650527 Use to hold 5th Lens Group in Tool No. 3650533 when centering Lens Group in Lens Group frame.



3650528 Centering microscope.



3650529 Use to remove/replace Diaphragm Ring Retainer O-M Mount.



3650531 Use to confirm F/stop settings – Canon Mount, see Special Instructions.



3650530 Use to position stop plates – Canon Mount.

VIVITAR TOOLS FOR SERIES 1 35-85 VARIFOCAL LENS



3650532 Use to set position and height of diaphragm coupling arm - Olympus Mount.

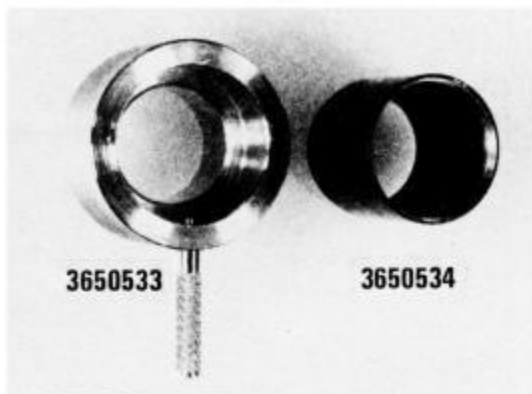

3650533

3650534

3650533 Use to hold Lens Group positioning tools.

3650534 Use as an elevating spacer with 3650533.

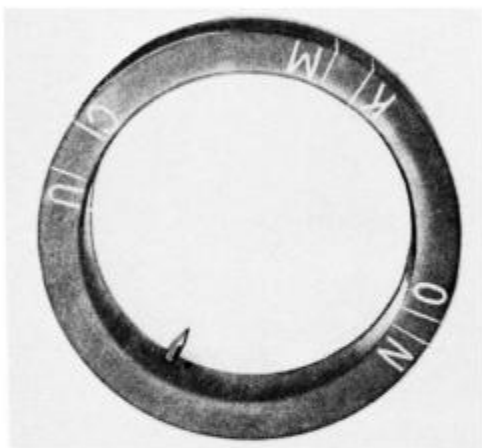

3650535 Use to set diaphragm lever to correct angle for rear mount assembly. All mounts.



3650536



3650550

3650536 Use to place scribe lines on Helicoid.

3650550 Helicoid Assembly Tool.

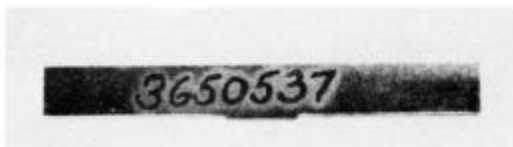

3650537 Use to set depth of inner and outer Helicoids.



3650557 F/Stop Gauge.

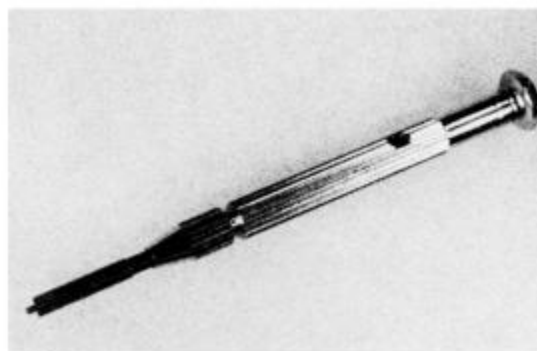

3650538 Use to remove/replace roller shafts in 2nd Lens Group slide housing.

12.0 ILLUSTRATED PARTS LIST

This section contains exploded view drawings with an index number at each illustrated part. A parts list, either on the same page or a facing page, is keyed to the index numbers and gives the part numbers, the description and the quantities for each part. If the part is not available separately, and can only be obtained by ordering the next higher assembly, this fact is indicated by the letters NAS or by an asterisk and a note. At the end of the section, there is a summary parts list in Vivitar part number sequence which indicates the parts quantity usage for each of the eight mount configurations.

The first exploded view illustration shows optical parts and helicoid and lens tube parts that are common to all mount configurations. The second exploded view illustration shows diaphragm housing assembly parts for all mount configurations. The remaining illustrations show the eight different mount configurations.

The listed parts are those in current production except for the Nikon F/Nikkormat mount. Other obsolete configurations are neither illustrated nor listed. The new parts are often interchangeable with the obsolete parts. When they are not, the new assemblies of which they are a part may be interchangeable with the old assemblies.

35-85mm f/2.8 Varifocal
Series 1 Lens

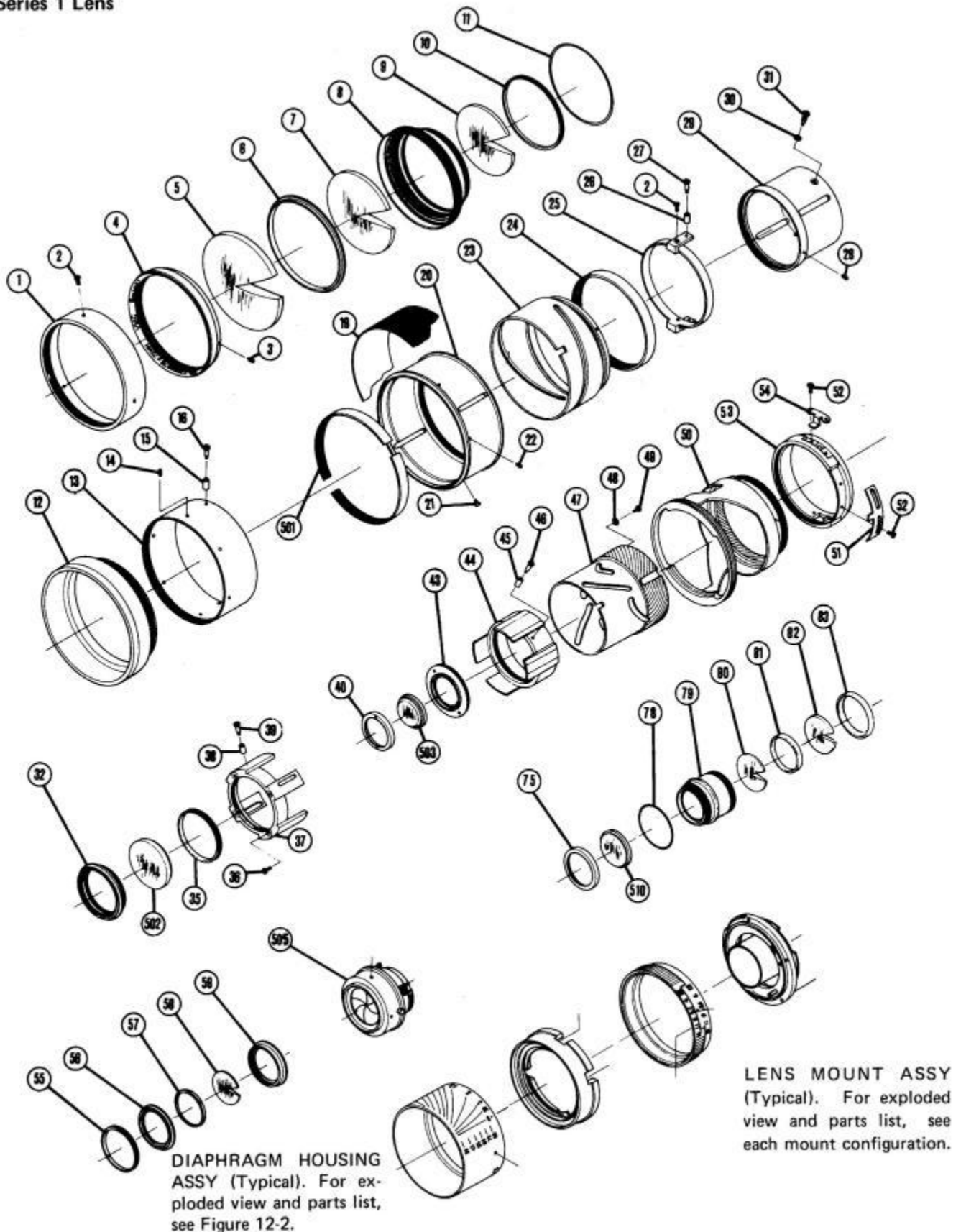

Figure 12-1. Parts Common to All Mount Configurations

Parts List for Figure 12-1. Parts Common to All Mount Configurations

Ref.	Vivitar Part No.	Description	Part Code		Quantity
1	3513799	FRAME, FILTER	Z38500	761025	1
2	3512985	SCREW, FLTHD, 1.7x2.5	Z75927	B760520	5
3	3513714	SETSCREW, 1.7x2.0	Z75902	B760520	2
4	3513800	RING, NAME	Z38501	761025	1
5	3513801	LENS ELEMENT, 1ST	G00081	761025	1
6	3513802	RING, SPACER, 1ST & 2ND ELEMENT	Z38502	761025	1
7	3513803	LENS ELEMENT, 2ND	G00082	761025	1
8	3513804	HOUSING, 1ST LENS GROUP	Z38503	761025	1
9	3513805	LENS ELEMENT, 3RD	G00083	761025	1
10	3513806	RING, RTNG, 1ST LENS GROUP	Z38504	761025	1
11	3513807-1	SHIM, FOCUS, FRONT, 0.1	Z38900	761025	1
11	3513807-2	SHIM, FOCUS, FRONT, 0.15	Z38941	761025	1
11	3513807-3	SHIM, FOCUS, FRONT, 0.2	Z38942	761025	1
12	3513664	RING, HOOD	Z38505	761025	1
13	3513665	RING, INNER FOCUSING	Z38506	761025	1
14	3513666	SETSCREW, 1.4x1.7	Z38901	B761025	1
15	3513668	ROLLER, CAM, CONTROL RING	Z38902	761025	2
16	3513667	SCREW, CAM ROLLER SHAFT	Z38903	761025	2
19	3513670	GRIP	Z38507	761025	1
20	3513669	RING B, ZOOM COLLAR	Z38508	761025	1
21	3512974	SCREW, FLTHD, 1.4x2.5x2.0	Z75912	B760520	8
22	3512752	SCREW, DRAG ADJUSTMENT	Z70905	761030	4
23	3513671	RING A, ZOOM COLLAR	Z38509	761025	1
24	3513672	RING, SEAL	Z38904	761025	1
25	3513673	RING, BRIDGE	Z38510	761025	1
26	3513675	ROLLER, CAM, BRIDGE RING	Z38905	761025	2
27	3513674	SCREW, BRIDGE ROLLER SHAFT	Z38906	761025	2
28	3512976	SETSCREW, 1.4x1.5	Z75905	B760520	1
29	3513676	HOUSING, 1ST LENS GROUP SLIDE	Z38511	761025	1
30	3513678	WASHER	Z38907	761025	2
31	3513677	SCREW, SLIDE, TAPERED	Z38908	761025	2
31	3513672	SCREW, SLIDE, STRAIGHT	Z38908	761025	2
32	3513808	HOUSING, 2ND LENS GROUP	Z38512	761025	1
35	3513810	RING, RTNG, 2ND LENS GROUP	Z38513	761025	1
36	3512840	SCREW, DIAPHRAGM CAM	Z85919	760615	4
37	3513679	HOUSING, 2ND LENS GROUP SLIDE	Z38514	761025	1
38	3513681	ROLLER, CAM SLOT, 2ND LENS GROUP	Z15903	760830	2
39	3513680	SCREW, CAM ROLLER SHAFT	Z38909	761025	2
40	3513811	RING, RTNG, 3RD LENS GROUP	Z38515	761025	1
43	3513813	CELL, 3RD LENS GROUP	Z38516	761025	1
44	3513682	HOUSING, 3RD LENS GROUP SLIDE	Z38517	761025	1
45	3513684	ROLLER, CAM, 3RD LENS GROUP	Z38910	761025	2
46	3513683	SCREW, CAM ROLLER SHAFT	Z38911	761025	2
47	3513685	HELICOID, INNER	Z38518	761025	1
48	3512894	WASHER	Z75958	760520	1
49	3513834	SCREW, FLTHD, 2.0x3.0	Z38912	B761025	3
50	3513686	HELICOID, MIDDLE	Z38519	761025	1
51	3513690	PLATE, INFINITY STOP	Z38700	761025	1
52	3512982	SCREW, PANHD, 1.7x2.5	Z75933	B760520	8
53	3513687	HELICOID, OUTER	Z38520	761025	1
54	3513689	GUIDE, HELICOID	Z38701	761025	2
55	3513693	RING, ADJUSTMENT RTNR	Z38521	761025	1
56	3513694	RING, ECCENTRIC	Z38522	761025	1
57	3513814	RING, RTNG, 8TH ELEMENT	Z38523	761025	1
58	3513815	LENS ELEMENT, 8TH	G00088	761025	1
59	3513816	HOUSING, 4TH LENS GROUP	Z38524	761025	1
75	3513817	RING, 9TH & 10TH LENS RTNG	Z38528	761025	1
78	3513819-1	SHIM, FOCUS, 0.1, REAR LENS GROUP	Z38915	761025	1
78	3513819-2	SHIM, FOCUS, 0.2, REAR LENS GROUP	Z38943	761025	1
79	3513820	HOUSING, REAR LENS GROUP	Z38529	761025	1

continued on page 54

**35-85mm f/2.8 Varifocal
Series 1 Lens**

Parts List for Figure 12-1. Parts Common to All Mount Configurations (cont'd)

Ref.	Vivitar Part No.	Description	Part Code	Quantity
80	3513821	LENS ELEMENT, 11TH	G00091 761025	1
81	3513822	RING, SPACER, 11TH & 12TH ELEMENTS	Z38530 761025	1
82	3513823	LENS, ELEMENT, 12TH	G00092 761025	1
83	3513824	RING, RTNG, 12TH ELEMENT	Z38565 761025	1
501	3512750	PLATE, DRAG ADJUSTMENT	Z70U98 N761030	2
502	3513809	LENS DOUBLET, 4TH & 5TH ELEMENTS	Z38U99 N761025	1
503	3513817	LENS DOUBLET, 6TH & 7TH ELEMENTS	Z38U98 N761025	1

Diaphragm Housing Assemblies and Mount Assemblies Referenced in Figure 12-1.

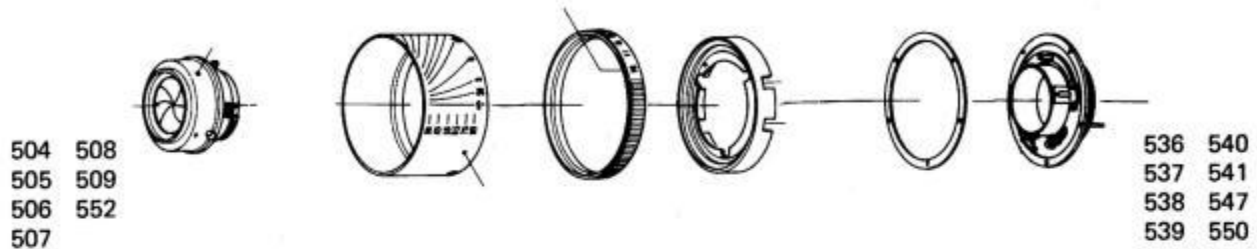

Figure 12-1A. Diaphragm Housing Assemblies and Mount Assemblies

Parts List for Figure 12-1A

Ref.	Vivitar Part No.	Description	Part Code	Quantity
504	3513827	DIAPHRAGM HOUSING ASSY, UNIV	Z38U95 N761025	1
505	3513699	DIAPHRAGM HOUSING ASSY, N/F, AI	Z38N95 N761025	1
506	3513836-1	DIAPHRAGM HOUSING ASSY, MINOLTA	Z38M95 N761025	1
507	3513836-2	DIAPHRAGM HOUSING ASSY, CANON	Z38C95 N761025	1
508	3513836-3	DIAPHRAGM HOUSING ASSY, KONICA	Z38K95 N761025	1
509	3513828	DIAPHRAGM HOUSING ASSY, OLYMPUS	Z38O95 N761025	1
552	3103821	DIAPHRAGM HOUSING ASSY, P/K	Z38P95 N770714	1
536	3513831	MOUNT ASSY, COMPLETE, UNIV	Z38U65 N761025	1
537	3513832	MOUNT ASSY, COMPLETE, N/F	Z38N65 N761025	1
538	3513833	MOUNT ASSY, COMPLETE, MINOLTA	Z38M65 N761025	1
539	3513834	MOUNT ASSY, COMPLETE, CANON	Z38C65 N761025	1
540	3514301	MOUNT ASSY, COMPLETE, KONICA	Z38K65 N761025	1
541	3513835	MOUNT ASSY, COMPLETE, O/OM	Z38O65 N761025	1
547	3103820	MOUNT ASSY, COMPLETE, P/K	Z38P65 N770228	1
550	3103807	MOUNT ASSY, COMPLETE, N/AI	Z38F65 N770520	1

ADDITIONAL ASSEMBLIES

The following additional assemblies are normally stocked. Parts that comprise these assemblies are illustrated and referenced in Figure 12-1 and its associated Parts List. The assemblies are not separately illustrated.

Vivitar Part No.	Description	Part Code	Ref. No.'s Of Included Parts
3514302	HELICOID ASSY	Z38U80 N761025	47, 48, 49, 50, 51, 52, 53, 54
3513829	LENS GROUP ASSY, 1ST	Z38U90 N761025	1, 2, 3, 4, 5, 6, 7, 8, 9, 10, 11
3103827	LENS GROUP ASSY, 2ND	Z38U89 N761025	32, 35, 502
3103826	LENS GROUP ASSY, 3RD	Z38U88 N761025	40, 41, 42, 43, 503
3103825	LENS GROUP ASSY, 4TH	Z38U87 N761025	55, 56, 57, 58, 59
3513830	LENS GROUP ASSY, 5TH	Z38U85 N761025	75, 78, 79, 80, 81, 82, 83, 510

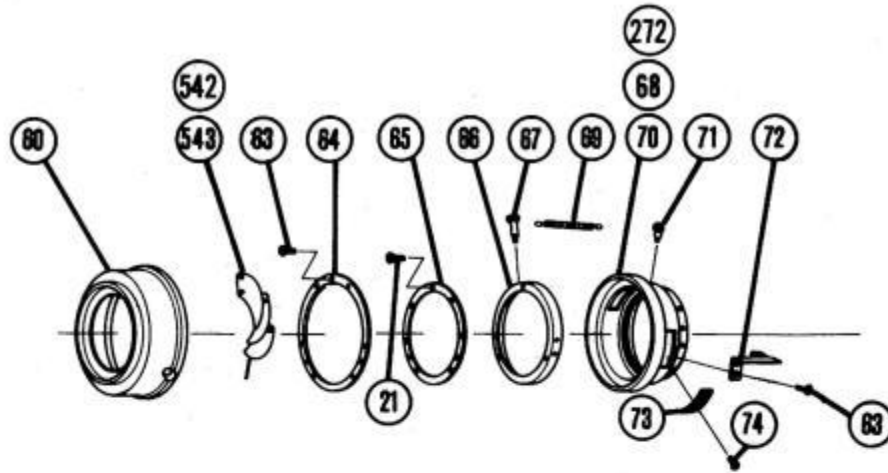

Figure 12-2. Diaphragm Housing Assembly, All Mounts
(Ref 504, 505, 506, 507, 508, 509, 552, Pg 55)

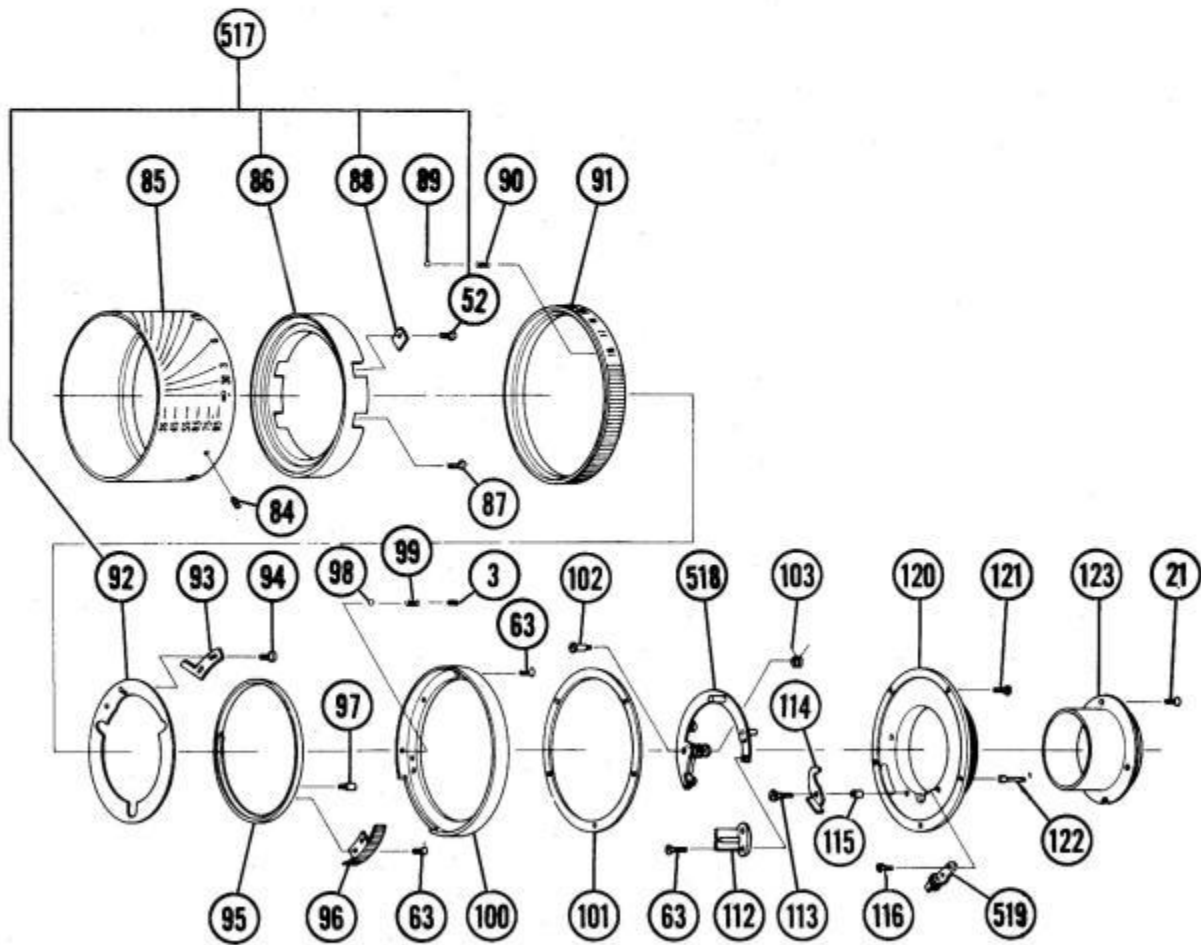

Figure 12-3. Universal Mount Assembly, Complete (Ref 536, Pg 55)

**Parts List for Figure 12-2. Diaphragm Housing Assembly,
All Mounts, Complete**

**35-85mm f/2.8 Varifocal
Series 1 Lens**

Ref.	Vivitar Part No.	Description	Part Code	Quantity
21	3512974	SCREW, FLTHD, 1.4x2.5x2.0	Z75912 B760520	8
60	3513695	HOUSING, DIAPHRAGM, FRONT	Z38525 761025	1
63	3513859	SCREW, FLTHD, 1.4x2.5	Z75963 B760520	7
64	3513697	RING, DIAPHRAGM BLADE	Z38704 761025	1
65	3513698	RING, DIAPHRAGM BLADE ACTUATOR	Z38705 761025	1
66	3513700	RING, BLADE ACTUATOR BASE	Z38526 761025	1
67	3512782	SCREW, SPRING POST	Z75946 760520	1
68	3513701	SPRING, DIAPHRAGM	W25901 760817	1
69	3103835	SPRING, DIAPHRAGM	Z38913 761025	1
70	3513702	HOUSING, DIAPHRAGM, REAR	Z38527 761025	1
71	3512835	SCREW, SPRING POST	Z75914 760520	1
72	3513704	ARM, DIAPHRAGM ACTUATOR	Z38706 761025	1
73	3513703	PLATE, DIAPHRAGM LIMIT STOP	Z38707 761025	1
74	3101360	SCREW, PANHD, 1.4x2.5	Z38914 B761025	1
272	3104012	SPRING, DIAPHRAGM	Z38939 761025	1
542	3103822	BLADE, DIAPHRAGM, U, N, O, N/AI	Z38U55 N761025	6
543	3103812	BLADE, DIAPHRAGM, M, C, K, P	Z38M55 N761025	6

Parts List for Figure 12-3. Universal Mount Assembly, Complete

Ref.	Vivitar Part No.	Description	Part Code	Quantity
3	3513714	SETSCREW, 1.7x2.0	Z75902 B760520	2
21	3512974	SCREW, FLTHD, 1.4x2.5x2.0	Z75912 B760520	8
52	3512982	SCREW, PANHD, 1.7x2.5	Z75933 B760520	8
63	3513859	SCREW, FLTHD, 1.4x2.5	Z75963 B760520	12
84	3512988	SETSCREW, 1.4x2.5	W25903 B760817	3
85	3513691-1	RING, INDEX, UNIV	Z38531UB761025	1
86	3513706	FRAME, MOUNT, UNIV	Z38566 761025	1
87	3512989	SCREW, PANHD, 1.7x2.5	Z75947 B760520	4
88	3513707	PLATE, CAM RETAINER	Z38708 761025	3
89	3512898	BALL, STEEL, 1.6	Z75919 760520	1
90	3512857	SPRING, DETENT, 1.5	Z75920 760520	1
91	3513708	RING, APERTURE SETTING, UNIV	Z38532UB761025	1
92	3513709	RING, APERTURE CAM	Z38735 761025	1
93	3103832	LUG, CAM RING	Z38709 761025	1
94	3512990	SCREW, PANHD, 1.4x2.5x2.0	Z75952 B760520	2
95	3513710	RING, AUTO/MANUAL SELECT	Z38533 761025	1
96	3513712	BUTTON, AUTO/MANUAL SELECT	Z38534 761025	1
97	3513711	SCREW, STOP	Z38916 761025	1
98	3512899	BALL, STEEL, 1.2	Z75941 760520	1
99	3513713	SPRING, DETENT, 1.2	Z75964 760520	1
100	3513716	RETAINER, APERTURE RING	Z38535 761025	1
101	3513717-1	SHIM, FOCUS, 0.1, UNIV	Z38917 761025	1
101	3513712-2	SHIM, FOCUS, 0.15, UNIV	Z38944 761025	1
101	3513717-3	SHIM, FOCUS, 0.2, UNIV	Z38945 761025	1
102	3102986	SCREW, PIVOT, DIAPHRAGM LEVER	W25907 760817	1
103	3513719	SPRING, DIAPHRAGM LEVER	W25906 760817	1
112	3513720	ARM, AUTO DIAPHRAGM ACTUATOR	Z38712 761025	1
113	3102988	SCREW, PIVOT, TRANSFER LEVER	W25908 760817	1
114	3102989	LEVER, AUTO DIAPHRAGM TRANSFER	W25710 760817	1
115	3102990	BUSHING, PIVOT SCREW	W25804 760817	1
116	3513725	SCREW, PANHD, 1.4x2.5, BLK	Z85910 B760615	2
120	3513724	MOUNT, UNIVERSAL	Z38536 761025	1
121	3512939	SCREW, PANHD, 1.7x3.0	Z38918 B761025	1
122	3102993	PIN, DIAPHRAGM CONTROL COUPLING	Z38801 761025	1
123	3513727	PIPE, SHADE	Z38537 761025	1
517	3103824	MOUNT FRAME ASSY, UNIV	Z38U84 N761025	1
518	3513718	LEVER, AUTO DIAPHRAGM	Z38U75 N761025	1
519	3513726	CRANK, AUTO DIAPHRAGM TRANSFER	Z38U74 N761025	1
534	3514303	APERTURE CAM RING ASSY, UNIV	Z75U61 N760520	1

35-85mm f/2.8 Varifocal
Series 1 Lens

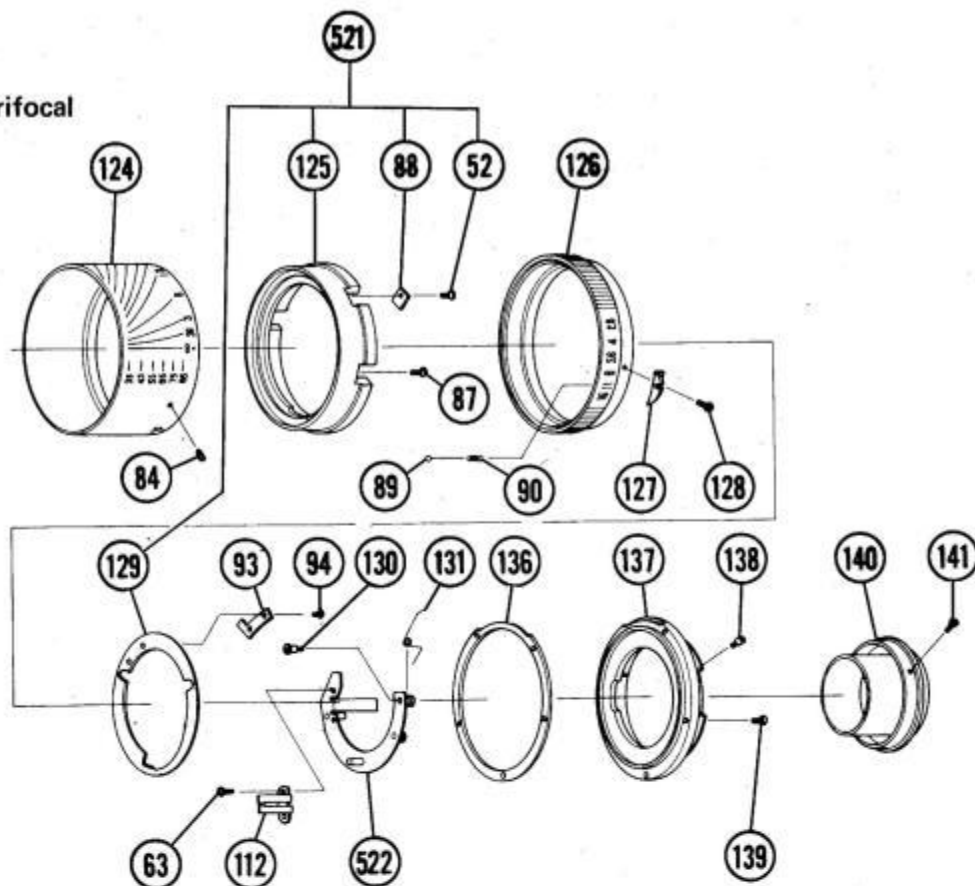

Figure 12-4. Nikon F / Nikkormat Mount Assembly, Complete
(Ref 537, Pg 55)

Parts List for Figure 12-4

Ref.	Vivitar Part No.	Description	Part Code	Quantity
52	3512982	SCREW, PANHD, 1.7x2.5	Z75933 B760520	8
63	3513859	SCREW, FLTHD, 1.4x2.5	Z75963 B760520	7
84	3512988	SETSCREW, 1.4x2.5	W25903 B760817	1
87	3512989	SCREW, PANHD, 1.7x2.5	Z75947 B760520	4
88	3513707	PLATE, CAM RETAINER	Z38708 761025	3
89	3512898	BALL, STEEL, 1.6	Z75919 760520	1
90	3512857	SPRING, DETENT, 1.5	Z75920 760520	1
93	3103832	LUG, CAM RING	Z38709 761025	1
94	3512990	SCREW, PANHD, 1.4x2.5x2.0	Z75952 B760520	2
112	3513720	ARM, AUTO DIAPHRAGM ACTUATOR	Z38712 761025	1
124	3513691-2	RING, INDEX, N/F	Z38531NB761025	1
125	3513728	FRAME, MOUNT, N/F	Z38538 761025	1
126	3513729	RING, APERTURE SETTING	Z38539NB761025	1
127	3512817	FORK, METER COUPLING	Z75716 760520	1
128	3512818	SCREW, METER COUPLING FORK	Z75928 760520	1
129	3513730	RING, APERTURE CAM	Z38713 761025	1
130	3512828	SCREW, PIVOT, DIAPHRAGM LEVER	Z75930 760520	1
131	3513845	SPRING, AUTO DIAPHRAGM LEVER	Z75931 760520	1
136	3512822-1	SHIM, FOCUS, 0.1, N/F	Z70917 761030	1
136	3512822-2	SHIM, FOCUS, 0.15, N/F	Z70927 761030	1
136	3512822-3	SHIM, FOCUS, 0.2, N/F	Z70928 761030	1
137	3512824	MOUNT, N/F	Z75543 760520	1
138	3512825	SCREW, MOUNT STOP	Z75934 W760520	1
139	3512971	SCREW, PANHD, 1.7x2.5	W25923 W760817	5
140	3513732	PIPE, SHADE, NIKON	Z38540 761025	1
141	3514089	SCREW, FLTHD, 1.4x2.0, CHR	Z75912 W760520	2
521	3103817	MOUNT FRAME ASSY, N/F & N/AI	Z38N84 N761025	1
522	3513731	LEVER, AUTO DIAPHRAGM	Z38N75 N761025	1

35-85mm f/2.8 Varifocal
Series 1 Lens

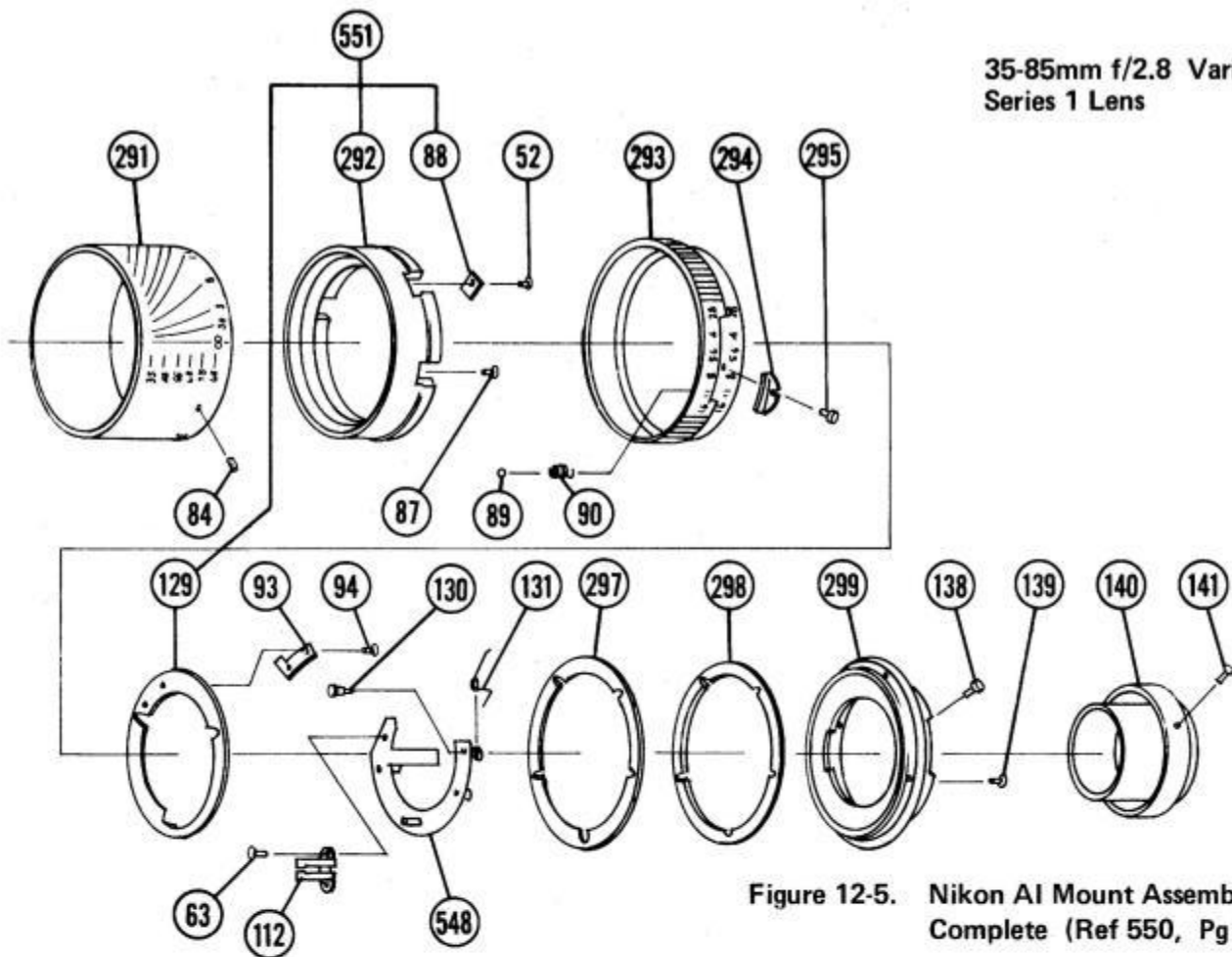

Figure 12-5. Nikon AI Mount Assembly,
Complete (Ref 550, Pg 55)

Parts List for Figure 12-5.

Ref.	Vivitar Part No.	Description	Part Code	Quantity
52	3512982	SCREW, PANHD, 1.7x2.5	Z75933 B760520	8
63	3513859	SCREW, FLTHD, 1.4x2.5	Z75963 B760520	7
84	3512988	SETSCREW, 1.4x2.5	W25903 B760817	3
87	3512989	SCREW, PANHD, 1.7x2.5	Z75947 B760520	4
88	3513707	PLATE, CAM RETAINER	Z38708 761025	3
89	3512898	BALL, STEEL, 1.6	Z75919 760520	1
90	3512857	SPRING, DETENT, 1.5	Z75920 760520	1
93	3103832	LUG, CAM RING	Z38709 761025	1
94	3512990	SCREW, PANHD, 1.4x2.5x2.0	Z75952 B760520	2
112	3513720	ARM, AUTO DIAPHRAGM ACTUATOR	Z38712 761025	1
129	3513730	RING, APERTURE CAM	Z38713 761025	1
130	3512828	SCREW, PIVOT, DIAPHRAGM LEVER	Z75930 760520	1
131	3513845	SPRING, AUTO DIAPHRAGM LEVER	Z75931 760520	1
138	3512825	SCREW, MOUNT STOP	Z75934 W760520	1
139	3512971	SCREW, PANHD, 1.7x2.5	W25923 W760817	5
140	3513732	PIPE, SHADE, NIKON	Z38540 761025	1
141	3514089	SCREW, FLTHD, 1.4x2.0, CHR	Z75912 W760520	2
291	3513691-8	RING, INDEX, N/AI	Z38531FB770520	1
292	3103829	FRAME, MOUNT, N/AI	Z38570 770520	1
293	3103830	RING, APERTURE SETTING, N/AI	Z38571FB770520	1
294	3518107	FORK, METER COUPLING	Z75747 770520	1
295	3518108	SCREW, METER COUPLING FORK	Z15917 770520	1
297	3518109	SHIM, FOCUS, 0.5, N/AI	Z70937 770520	1
298	3518110-1	SHIM, FOCUS, 0.2, N/AI	Z70938 770520	1
298	3518110-2	SHIM, FOCUS, 0.15, N/AI	Z70939 770520	1
298	3518110-3	SHIM, FOCUS, 0.1, N/AI	Z70940 770520	1
299	3518112	MOUNT, N/AI	Z75588 770520	1
548	3103809	LEVER, AUTO DIAPHRAGM	Z38F75 N770520	1
551	3103810	MOUNT FRAME ASSY, N/AI	Z38F84 N770520	1

35-85mm f/2.8 Varifocal
Series 1 Lens

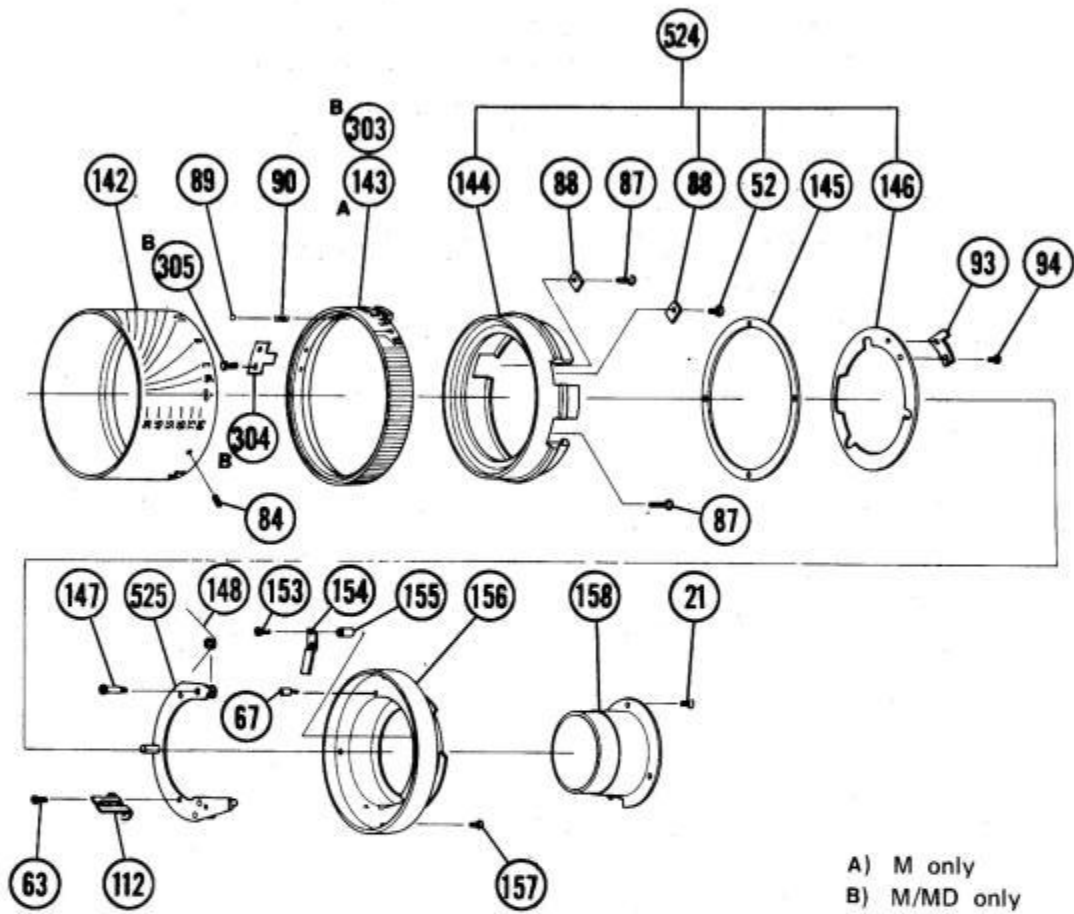

Figure 12-6. Minolta MD, SRT, SR Mount Assembly, Complete
(Ref 538, Pg 55)

Parts List for Figure 12-6. Minolta MD, SRT, SR Mount Assembly, Complete

Ref.	Vivitar Part No.	Description	Part Code	Quantity
21	3512974	SCREW, FLTHD, 1.4x2.5x2.0	Z75912 B760520	8
52	3512982	SCREW, PANHD, 1.7x2.5	Z75933 B760520	8
63	3513859	SCREW, FLTHD, 1.4x2.5	Z75963 B760520	7
67	3512782	SCREW, SPRING POST	Z75946 760520	1
84	3512988	SETSCREW, 1.4x2.5	W25903 B760817	1
87	3512989	SCREW, PANHD, 1.7x2.5	Z75947 B760520	4
88	3513707	PLATE, CAM RETAINER	Z38708 761025	1
89	3512898	BALL, STEEL, 1.6	Z75919 760520	1
90	3512857	SPRING, DETENT, 1.5	Z75920 760520	1
93	3103832	LUG, CAM RING	Z38709 761025	1
94	3512990	SCREW, PANHD, 1.4x1.5x2.0	Z75952 B760520	2
112	3513720	ARM, AUTO DIAPHRAGM ACTUATOR	Z38712 761025	1
142	3513691-3	RING, INDEX, MINOLTA	Z38531MB771215	1
143	3513733	RING, APERTURE SETTING	Z38541MB770514	1
144	3513734	FRAME, MOUNT, MINOLTA	Z38542 761025	1
145	3512837-1	SHIM, FOCUS, 0.1, M	Z70918 761030	1
145	3512837-2	SHIM, FOCUS, 0.15, M	Z70929 761030	1
145	3512837-3	SHIM, FOCUS, 0.2, M	Z70930 761030	1
146	3513735	RING, APERTURE CAM	Z38715 761025	1
147	3513737	SCREW, PIVOT, DIAPHRAGM LEVER	Z38803 761025	1
148	3513738	SPRING, DIAPHRAGM ACTUATOR LEVER	Z38919 761025	1
153	3513739	SCREW, PANHD, 1.4x2.5	Z38920 B761025	2
154	3512839	PLATE, GUIDE, DIAPHRAGM LEVER	Z75721 760520	1
155	3513740	SPACER, GUIDE PLATE	Z38921 761025	2
156	3513741	MOUNT, MINOLTA	Z38543 770514	1
157	3513742	SCREW, PANHD, 1.7x3.0, CHR	Z38922 W761025	4
158	3513743	PIPE, SHADE	Z38544 761025	1
303	3103831	RING, APERTURE SETTING, M/MD	Z38572 771215	1
304	3103839	LUG, APERTURE COUPLING, M/MD	Z38953 771215	1
305	3101632	SCREW, PANHD, 1.4x2.2x3.0, BLK	Z15921 B771215	2
524	3103815	MOUNT FRAME ASSY, M/MD	Z38M84 N761025	1
525	3513736	LEVER, AUTO DIAPHRAGM, M & MD	Z38M75 N761025	1
553	3103813	MOUNT ASSY, COMPLETE, M/MD	Z38M64 N771215	1

35-85mm f/2.8 Varifocal
Series 1 Lens

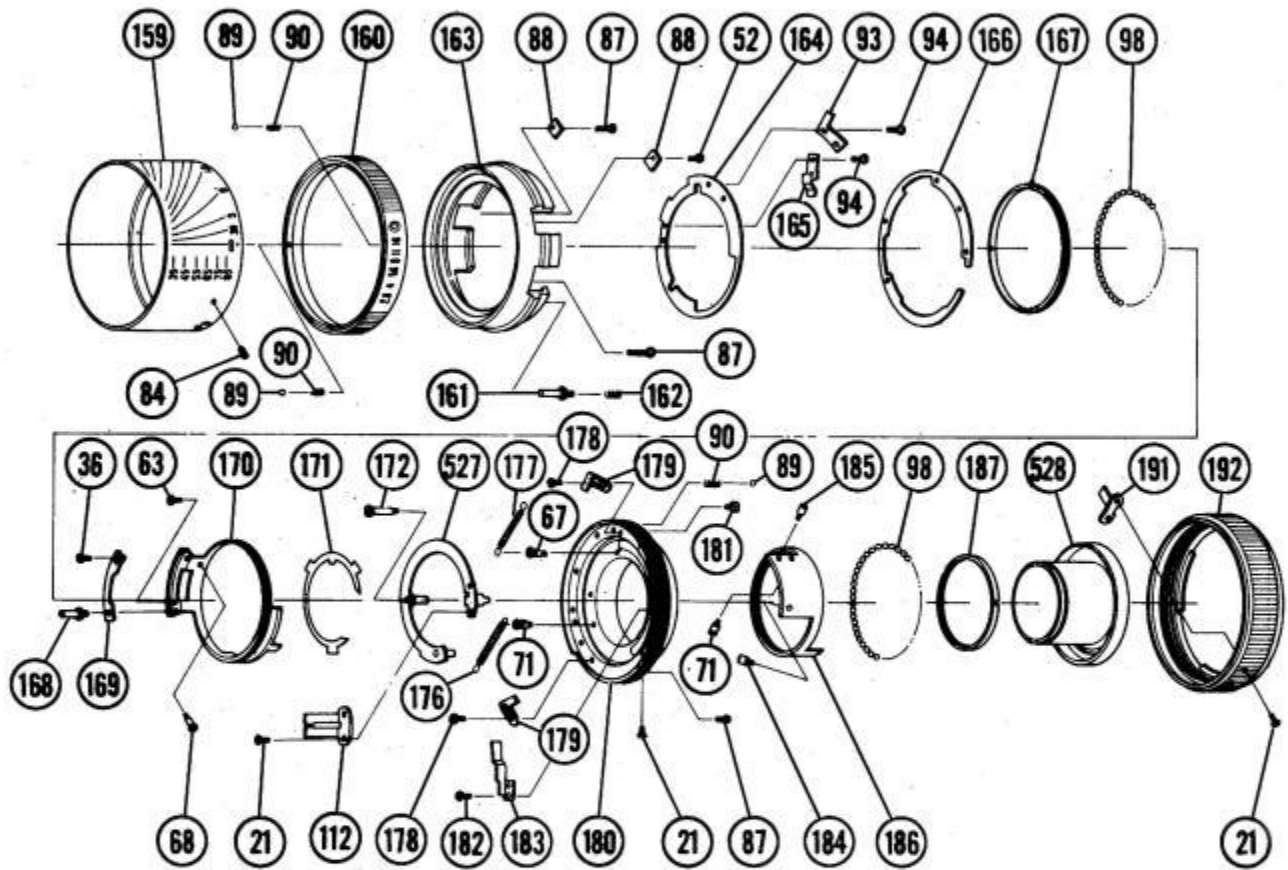

Figure 12-7. Canon FL, FD Mount Assembly, Complete (Ref 539, Pg 55)

Parts List for Figure 12-7. Canon FL, FD Mount Assembly, Complete

Ref.	Vivitar Part No.	Description	Part Code	Quantity
21	3512974	SCREW, FLTHD, 1.4x2.5x2.0	Z75912 B760520	12
36	3512840	SCREW, DIAPHRAGM CAM	Z85919 760615	1
52	3512982	SCREW, PANHD, 1.7x2.5	Z75933 B760520	8
63	3513859	SCREW, FLTHD, 1.4x2.5	Z75963 B760520	6
67	3512782	SCREW, SPRING POST	Z75946 760520	1
71	3512835	SCREW, SPRING POST	Z75914 760520	1
84	3512988	SETSCREW, 1.4x2.5	W25903 B760817	3
87	3512989	SCREW, PANHD, 1.7x2.5	Z75947 B760520	9
88	3513707	PLATE, CAM RETAINER	Z38708 761025	3
89	3512898	BALL, STEEL, 1.6	Z75919 760520	3
90	3512857	SPRING, DETENT, 1.5	Z75920 760520	3
93	3103832	LUG, CAM RING	Z38709 761025	1
94	3512990	SCREW, PANHD, 1.4x1.5x2.0	Z75952 B760520	4
98	3512899	BALL, STEEL, 1.2	Z75941 760520	120
112	3513720	ARM, AUTO DIAPHRAGM ACTUATOR	Z38712 761025	1
159	3513691-4	RING, INDEX, CANON	Z38531CB761025	1
160	3513744	RING, DIAPHRAGM SETTING	Z38545CB761025	1
161	3512849	PIN, EE SIGNAL	Z75817 760520	1
162	3512850	SPRING, EE SIGNAL PIN	Z75940 760520	1
163	3513745	FRAME, MOUNT, CANON	Z38546 761025	1
164	3513746	RING, APERTURE CAM	Z38717 761025	1
165	3513747	PLATE, LATCH	Z38718 761025	1
166	3512748-1	SHIM, FOCUS, 0.1, CANON	Z38923 761025	1
166	3513748-2	SHIM, FOCUS, 0.15, CANON	Z38946 761025	1
166	3513748-3	SHIM, FOCUS, 0.2, CANON	Z38947 761025	1
167	3513749	RING, BALL RTNR	W25539 760817	1
168	3513751	SCREW, DIAPHRAGM COUPLING	Z38924 761025	1
169	3513752	CAM, APERTURE	Z38719 761025	1
170	3513753	RING, APERTURE SIGNAL	Z38547 761025	1
171	3513754	RETAINER, SIGNAL RING	Z38720 761025	1
172	3513755	SCREW, PIVOT, DIAPHRAGM LEVER	W25916 760817	1
176	3513837	SPRING, COIL, TENSION	Z38938 761025	1
177	3513758	SPRING, COIL, TENSION	Z38940 761025	1
178	3513757	SCREW, STOP PLATE	W25922 760817	4
179	3513759	PLATE, STOP	W25721 760817	2
180	3513760	MOUNT, CANON	Z38548 761025	1
181	3512825	SCREW, MOUNT STOP	Z75934 B760520	1
182	3512984	SCREW, PANHD, 1.4x2.5x2.0	Z75922 B760520	2
183	3512866	SPRING, LEAF, DETENT	Z75726 760520	1
184	3512909	SCREW, AUTO DIAPHRAGM RING	Z75967 750520	1
185	3512864	SCREW, DETENT	Z75950 760520	1
186	3513761	RING, AUTO DIAPHRAGM	Z38549 761025	1
187	3513762	RING, BALL RTNG	W25543 760817	1
191	3513764	LUG, BREECHLOCK SIGNAL	W25722 760817	1
192	3513765	RING, BREECHLOCK	Z38551 761025	1
527	3513756	LEVER, AUTO DIAPHRAGM	Z38C75 N761025	1

35-85mm f/2.8 Varifocal
Series 1 Lens

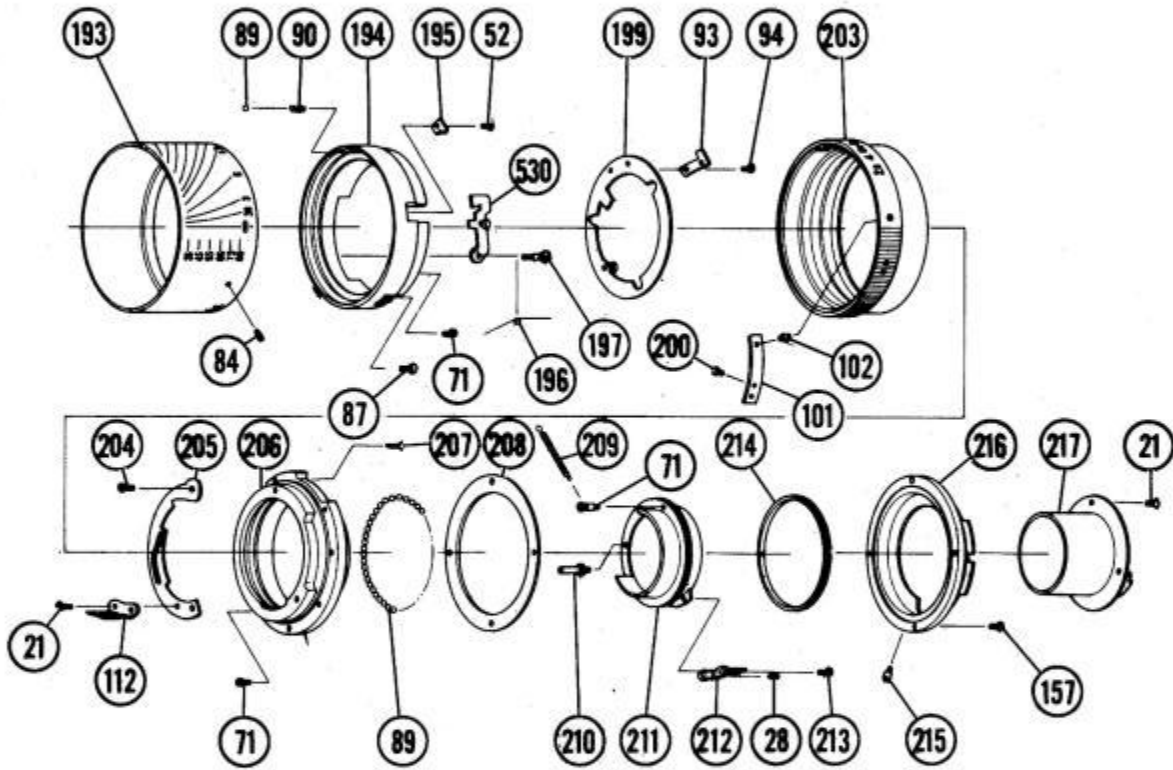

Figure 12-8. Konicaflex Mount Assembly, Complete (Ref 540, Pg 55)

Parts List for Figure 12-8. Konica Autoreflex Mount Assembly, Complete

Ref.	Vivitar Part No.	Description	Part Code	Quantity
21	3512974	SCREW, FLTHD, 1.4x2.5x2.0	Z75912 B760520	10
28	3512976	SETSCREW, 1.4x1.5	Z75905 B760520	2
52	3512982	SCREW, PANHD, 1.7x2.5	Z75933 B760520	8
71	3512835	SCREW, SPRING POST	Z75914 760520	4
84	3512988	SETSCREW, 1.4x2.5	W25903 B760817	3
87	3512989	SCREW, PANHD, 1.7x2.5	Z75947 B760520	4
89	3512898	BALL, STEEL, 1.6	Z75919 760520	60
90	3512857	SPRING, DETENT, 1.5	Z75920 760520	1
93	3103832	LUG, CAM RING	Z38709 761025	1
94	3512990	SCREW, PANHD, 1.4x1.5x2.0	Z75952 B760520	2
112	3513720	ARM, AUTO DIAPHRAGM ACTUATOR	Z38712 761025	1
157	3513742	SCREW, PANHD, 1.7x3.0, CHR	Z38922 W761025	4
193	3513691-6	RING, INDEX, K/AR	Z38531KB761025	1
194	3514043	FRAME, INTERMEDIATE, K/AR	Z38552 761025	1
195	3514045	PLATE, CAM RTNR	Z38722 761025	3
196	3513688	SPRING, EE PIN	Z38925 761025	1
197	3514047	SCREW, PIVOT, EE SIGNAL LEVER	Z38926 761025	1
199	3514048	RING, APERTURE CAM	Z38724 761025	1
200	3512986	SCREW, PANHD, 1.4x2.0	Z75926 B760520	1
201	3514282	SPRING, EE LATCH RELEASE	Z38725 761025	1
202	3514281	BUTTON, EE LATCH RELEASE	Z38807 761025	1
203	3514280	RING, APERTURE SETTING	Z38553KB761025	1
204	3512872	SCREW, PIVOT, DIAPHRAGM LEVER	Z75951 760520	1
205	3514285	LEVER, AUTO DIAPHRAGM	Z38726 761025	1
206	3514286	FRAME, MOUNT, K/AR	Z38554 761025	1
207	3512975	SCREW, COUNTERSUNK, 1.7x2.5	Z38927 W761025	4
208	3514287-1	SHIM, FOCUS, REAR, 0.1, KONICA	Z38928 761025	1
208	3514287-2	SHIM, FOCUS, REAR, 0.15, KONICA	Z38948 761025	1
208	3514287-4	SHIM, FOCUS, REAR, 0.2, KONICA	Z38949 761025	1
209	3512885	SPRING, COIL, TENSION, 2.5x27.0	Z75957 760520	1
210	3513549	SHAFT, CAM OPERATING	Z38929 761025	1
211	3103828	RING, AUTO DIAPHRAGM	Z38555 761025	1
212	3513548	ARM, AUTO DIAPHRAGM COUPLING	Z38727 761025	1
213	3512980	SCREW, PANHD, 1.7x3.0x3.0	Z75913 B760520	2
214	3513462	RING, BALL RTNG	Z38556 761025	1
215	3512891	SCREW, MOUNT STOP	Z75961 760520	1
216	3513950	MOUNT, KONICA	W25552 760817	1
217	3514121	PIPE, SHADE	Z38557 761025	1
530	3514279	LEVER, EE SIGNAL	Z38K71 N761025	1

35-85mm f/2.8 Varifocal
Series 1 Lens

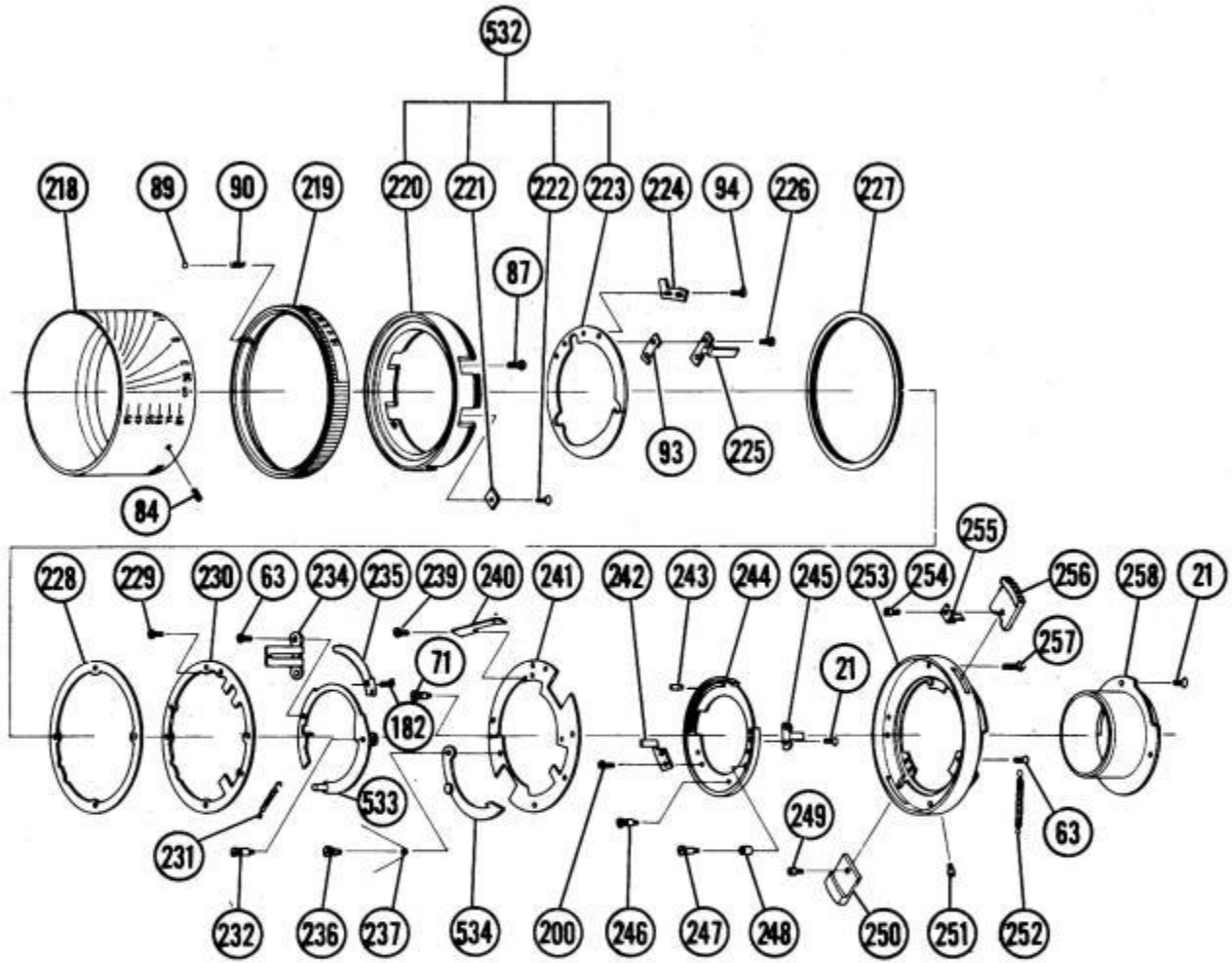

Figure 12-9. Olympus OM Mount Assembly, Complete (Ref 541, Pg 55)

Parts List for Figure 12-9. Olympus OM Mount Assembly, Complete

Ref.	Vivitar Part No.	Description	Part Code	Quantity
21	3512974	SCREW, FLTHD, 1.4x2.5x2.0	Z75912 B760520	10
63	3513859	SCREW, FLTHD, 1.4x2.5	Z75963 B760520	8
71	3512835	SCREW, SPRING POST	Z75914 760520	4
84	3512988	SETSCREW, 1.4x2.5	W25903 B760817	3
87	3512989	SCREW, PANHD, 1.7x2.5	Z75947 B760520	4
89	3512898	BALL, STEEL, 1.6	Z75919 760520	1
90	3512857	SPRING, DETENT, 1.5	Z75920 760520	1
93	3103832	LUG, CAM RING	Z38709 761025	1
94	3512990	SCREW, PANHD, 1.4x1.5x2.0	Z75952 B760520	2
182	3512984	SCREW, PANHD, 1.4x2.5x2.0	Z75922 B760520	2
200	3512986	SCREW, PANHD, 1.4x2.0x1.8	Z75926 B760520	1
218	3513691-5	RING, INDEX, O/OM	Z38531OB761025	1
219	3513766	RING, APERTURE SETTING	Z38558OB761025	1
220	3513767	FRAME, MOUNT, O/OM	Z38559 761025	1
221	3513768	PLATE, CAM RTNR	Z38728 761025	3
222	3513769	SCREW, FLTHD, 1.7x2.5	Z38931 B761025	3
223	3513770	RING, APERTURE CAM	Z38729 761025	1
224	3513771-1	SHIM, COUPLING ARM, 0.1	Z38937 761025	1
224	3513771-2	SHIM, COUPLING ARM, 0.15	Z38950 761025	1
224	3513771-3	SHIM, COUPLING ARM, 0.5	Z38951 761025	1
225	3513772	ARM, APERTURE SIGNAL COUPLING	Z38730 761025	1
226	3103836	SCREW, COUPLING ARM	Z38932 761025	2
227	3513773	RING, RTNG, APERTURE CAM	Z38560 761025	1
228	3513774-1	SHIM, FOCUS, 0.1, O/OM	Z70923 761030	1
228	3513774-2	SHIM, FOCUS, 0.15, O/OM	Z70933 761030	1
228	3513774-3	SHIM, FOCUS, 0.2, O/OM	Z70934 761030	1
229	3512987	SCREW, FLTHD, 1.4x2.0	Z75968 W760520	3
230	3513775	RING, LOCK BUTTON RTNG	Z75735 760520	1
231	3103838	SPRING, COIL, AUTO LEVER	Z38952 770620	1
232	3513777	SCREW, PIVOT, AUTO LEVER	Z38933 761025	1
234	3513776	ARM, AUTO DIAPHRAGM ACTUATOR	Z38732 761025	1
235	3103833	SPRING, FLAT	Z38733 761025	1
236	3513779	SCREW, PIVOT, MANUAL LEVER	Z38934 761025	1
237	3513780	SPRING, MANUAL LEVER	Z38935 761025	1
239	3101536	SCREW, LOCK RELEASE SPRING	Z15918 B770606	2
240	3513783	SPRING, LEAF, LOCK RELEASE	Z75737 760520	1
241	3513784	PLATE, GUIDE	W25732 760817	1
242	3513785	PLATE, DIAPHRAGM STOP	Z38734 761025	1
243	3103837	SCREW, STOP	Z38936 761025	1
244	3513788	RING, AUTO DIAPHRAGM	W25558 B760817	1
245	3512924	ARM, AUTO DIAPHRAGM COUPLING	Z75740 760520	1
246	3101633	SCREW, SPRING POST	W25932 760817	1
247	3513786	SCREW, CAM ROLLER	W25933 760817	1
248	3513787	ROLLER, CAM, MANUAL	W25934 760817	1
249	3512929	SCREW, MANUAL BUTTON	Z75974 760520	1
250	3101569	BUTTON, MANUAL, CHR	Z15808 780314	1
251	3512934	SCREW, STOP	Z75975 760520	1
252	3512923	SPRING, ACTUATING RING	W25939 760817	1
253	3513826	MOUNT, OLYMPUS	W25559 760817	1
254	3513792	SCREW, LOCK PLATE	W25936 760817	1
255	3512931	PLATE, MOUNT LOCKING	Z75741 760520	1
256	3101571	BUTTON, LOCK RELEASE, CHR	Z15807 780314	1
257	3518091	SCREW, PANHD, 1.7x5.0x2.9	Z75985 W760520	4
258	3513798	PIPE, SHADE	Z38561 761025	1
532	3103819	MOUNT FRAME ASSY, O/OM	Z38084 N761025	1
533	3513778	LEVER, AUTO DIAPHRAGM	Z38075 N761025	1
534	3513781	LEVER, MANUAL	Z38073 N761025	1

35-85mm f/2.8 Varifocal
Series 1 Lens

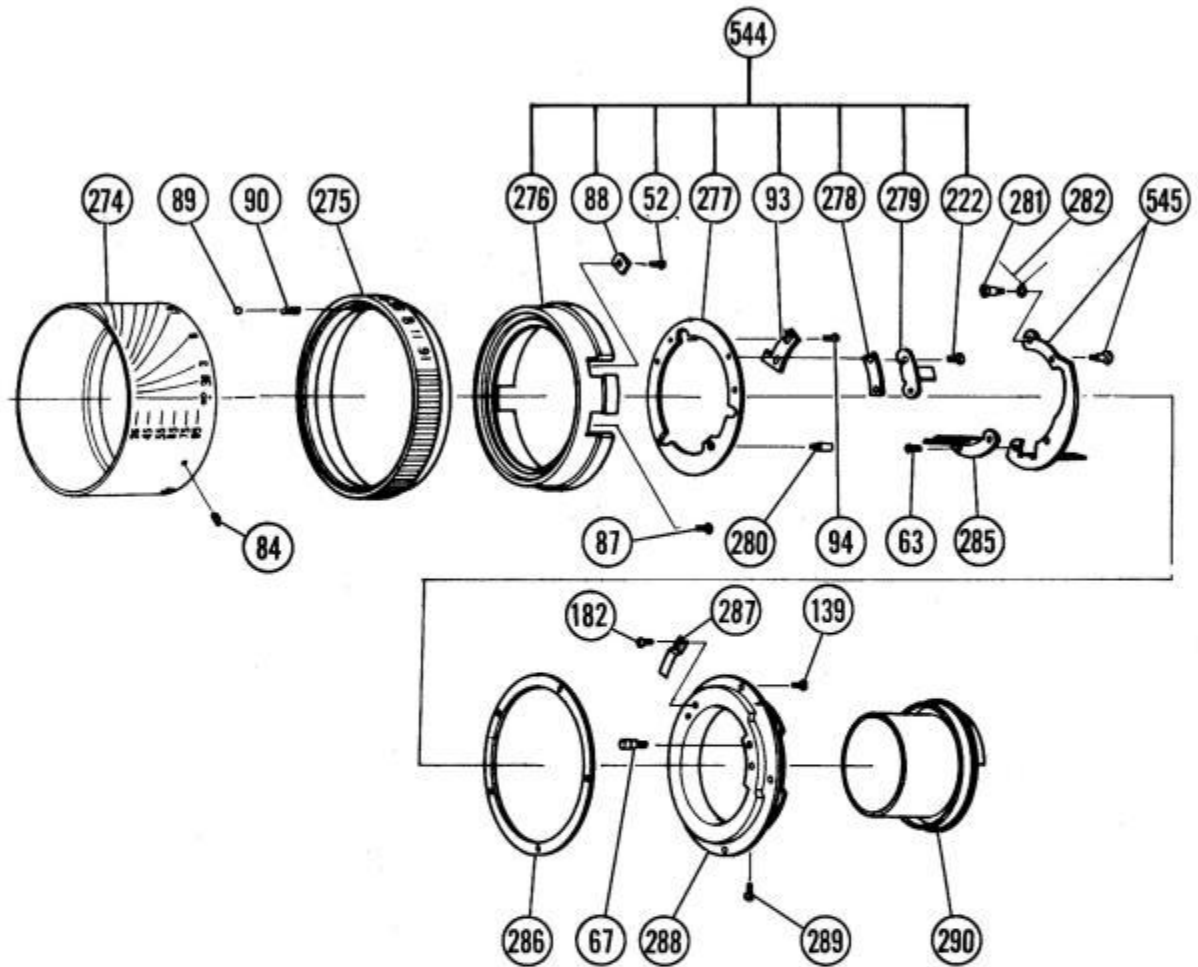

Figure 12-10. Pentax K Mount Assembly, Complete (Ref 547, Pg 55)

Parts List for Figure 12-10. Pentax K Mount Assembly, Complete

Ref.	Vivitar Part No.	Description	Part Code	Quantity
52	3512982	SCREW, PANHD, 1.7x2.5	Z75933 B760520	8
63	3513859	SCREW, FLTHD, 1.4x2.0	Z75963 B760520	7
67	3512782	SCREW, SPRING POST	Z75946 760520	1
84	3512988	SETSCREW, 1.4x2.5	W25903 B760817	3
87	3512989	SCREW, PANHD, 1.7x2.5	Z75947 B760520	4
88	3513707	PLATE, CAM RETAINER	Z38708 761025	3
89	3512898	BALL, STEEL, 1.6	Z75919 760520	1
90	3512857	SPRING, DETENT, 1.5	Z75920 760520	1
93	3103832	LUG, CAM RING	Z38709 761025	1
94	3512990	SCREW, PANHD, 1.4x1.5x2.0	Z75952 B760520	2
139	3512971	SCREW, PANHD, 1.7x2.5, CHR	W25923 W760817	5
182	3512984	SCREW, PANHD, 1.4x2.5x2.0	Z75922 B760520	2
222	3513769	SCREW, FLTHD, 1.7x2.5	Z38931 B761025	2
274	3513691-7	RING, INDEX, P/K	Z38531PB770228	1
275	3101373	RING, APERTURE SETTING, P/K	Z38569PB770228	1
276	3101374	FRAME, MOUNT	Z38568 770228	1
277	3101375	RING, APERTURE CAM	Z38737 770228	1
278	3518095	SHIM, APERTURE ARM	Z70941 770228	1
279	3518096	ARM, APERTURE COUPLING	Z75744 770228	1
280	3101378	PIN, APERTURE SIGNAL	Z38829 770228	1
281	3518100	SCREW, PIVOT, AUTO LEVER	K90916 770606	1
282	3518131	SPRING, WIRE, AUTO LEVER	K90917 770606	1
285	3101383	ARM, AUTO DIAPHRAGM ACTUATOR	Z38736 770228	1
286	3518098-1	SHIM, FOCUS, 0.2, P/K	Z70924 770228	1
286	3518098-2	SHIM, FOCUS, 0.15, P/K	Z70935 770228	1
286	3518098-3	SHIM, FOCUS, 0.1, P/K	Z70936 770228	1
287	3518101	PLATE, GUIDE, AUTO LEVER	Z75743 770228	1
288	3518102	MOUNT, P/K	Z70548 770228	1
289	3513901	SCREW, FLTHD, 1.4x2.0, CHR	Z75963 W760520	3
290	3101390	PIPE, SHADE	Z38567 770228	1
544	3101392	MOUNT FRAME ASSY, P/K	Z38P80 N770228	1
545	3101376	LEVER, AUTO DIAPHRAGM	Z38P75 N770228	1

35-85mm f/2.8 Varifocal
Series 1 Lens

COMPLETE PARTS LIST

Vivitar Part No.	Ref.	Description	Part Code	Quantity								
				U	N/F	M	C	K	O	P	N/AI	
3101360	74	SCREW, PANHD, 1.4x2.5	Z38914 B761025	1	1	1	1	1	1	1	1	1
3101373	275	RING, APERTURE SETTING, P/K	Z38569PB770228								1	
3101374	276	FRAME, MOUNT	Z38568 770228								1	
3101375	277	RING, APERTURE CAM	Z38737 770228								1	
3101376	545	LEVER, AUTO DIAPHRAGM	Z38P75 N770228								1	
3101378	280	PIN, APERTURE SIGNAL	Z38829 770228								1	
3101383	285	ARM, AUTO DIAPHRAGM ACTUATOR	Z38736 770228								1	
3101390	290	PIPE, SHADE	Z38567 770228								1	
3101392	544	MOUNT FRAME ASSY, P/K	Z38P80 N770228								1	
3101536	239	SCREW, LOCK RELEASE SPRING	Z15918 B770606							2		
3101569	250	BUTTON, MANUAL, CHR	Z15808 780314							1		
3101571	256	BUTTON, LOCK RELEASE, CHR	Z15807 780314							1		
3101632	305	SCREW, PANHD, 1.4x2.2x3.0, BLK	Z15921 B771215			2						
3101633	246	SCREW, SPRING POST	W25932 760817							1		
3102986	102	SCREW, PIVOT, DIAPHRAGM LEVER	W25907 760817	1								
3102988	113	SCREW, PIVOT, TRANSFER LEVER	W25908 760817	1								
3102989	114	LEVER, AUTO DIAPHRAGM TRANSFER	W25710 760817	1								
3102990	115	BUSHING, PIVOT SCREW	W25804 760817	1								
3102993	122	PIN, DIAPHRAGM CONTROL COUPLING	Z38801 761025	1								
3103807	550	MOUNT ASSY, COMPLETE, N/AI	Z38F65 N770520									1
3103809	548	LEVER, AUTO DIAPHRAGM	Z38F75 N770520									1
3103810	551	MOUNT FRAME ASSY, N/AI	Z38F84 N770520									1
3103812	543	BLADE, DIAPHRAGM, M, C, K, P	Z38M55 N761025			6	6	6			6	
3103813	553	MOUNT ASSY, COMPLETE, M/MD	Z38M64 N771215			1						
3103815	524	MOUNT FRAME ASSY, M/MD	Z38M84 N761025			1						
3103817	521	MOUNT FRAME ASSY, N/F & N/AI	Z38N84 N761025		1							1
3103819	532	MOUNT FRAME ASSY, O/OM	Z38O84 N761025						1			
3103820	547	MOUNT ASSY, COMPLETE, P/K	Z38P65 N770228								1	
3103821	552	DIAPHRAGM HOUSING ASSY, P/K	Z38P95 N770714								1	
3103822	542	BLADE, DIAPHRAGM, U, N, O, N/AI	Z38U55 N761025	6	6					6		6
3103824	517	MOUNT FRAME ASSY, UNIV	Z38U84 N761025	1								
3103825	514	LENS GROUP ASSY, 4TH	Z38U87 N761025	1	1	1	1	1	1	1	1	1
3103826	513	LENS GROUP ASSY, 3RD	Z38U88 N761025	1	1	1	1	1	1	1	1	1
3103827	512	LENS GROUP ASSY, 2ND	Z38U89 N761025	1	1	1	1	1	1	1	1	1
3103828	211	RING, AUTO DIAPHRAGM	Z38555 761025						1			
3103829	292	FRAME, MOUNT, N/AI	Z38570 770520									1
3103830	293	RING, APERTURE SETTING, N/AI	Z38571FB770520									1
3103831	303	RING, APERTURE SETTING, M/MD	Z38572 771215			1						
3103832	93	LUG, CAM RING	Z38709 771025	1	1	1	1	1	1	1	1	1
3103833	235	SPRING, FLAT	Z38733 761025							1		
3103834	49	SCREW, FLTHD, 2.0x3.0	Z38912 B761025	3	3	3	3	3	3	3	3	3
3103835	69	SPRING, DIAPHRAGM	Z38913 761025			1					1	
3103836	226	SCREW, COUPLING ARM	Z38932 761025							2		
3103837	243	SCREW, STOP	Z38936 761025							1		
3103838	231	SPRING, COIL, AUTO LEVER	Z38952 770620							1		
3103839	304	LUG, APERTURE COUPLING, M/MD	Z38953 771215			1						
3104012	272	SPRING, DIAPHRAGM	Z38939 761025							1		
3512750	501	PLATE, DRAG ADJUSTMENT	Z70U98 N761030	2	2	2	2	2	2	2	2	2
3512752	22	SCREW, DRAG ADJUSTMENT	Z70905 761030	4	4	4	4	4	4	4	4	4
3512782	67	SCREW, SPRING POST	Z75946 760520	1		1	1			1	1	
3512817	127	FORK, METER COUPLING	Z75716 760520		1							
3512818	128	SCREW, METER COUPLING FORK	Z75928 760520		1							
3512822-1	136	SHIM, FOCUS, 0.1, N/F	Z70917 761030		A/R							
3512822-2	136	SHIM, FOCUS, 0.15, N/F	Z70927 761030		A/R							
3512822-3	136	SHIM, FOCUS, 0.2, N/F	Z70928 761030		A/R							
3512824	137	MOUNT, N/F	Z75543 760520		1							
3512825	138	SCREW, MOUNT STOP	Z75934 W760520		1							1
3512825	181	SCREW, MOUNT STOP	Z75934 W760520				1					
3512828	130	SCREW, PIVOT, DIAPHRAGM LEVER	Z75930 760520		1							1
3512835	71	SCREW, SPRING POST	Z75914 760520	1		1	1			1		1

U N/F M C K O P N/AI

Complete Parts List, continued

Vivitar Part No.	Ref.	Description	Part Code	Quantity									
				U	N	M	C	K	O	P	N/AI		
3512837-1	145	SHIM, FOCUS, 0.1, M	Z70918 761030				A/R						
3512837-2	145	SHIM, FOCUS, 0.15, M	Z70929 761030				A/R						
3512837-3	145	SHIM, FOCUS, 0.2, M	Z70930 761030				A/R						
3512839	154	PLATE, GUIDE, DIAPHRAGM LEVER	Z75721 760520				1						
3512840	36	SCREW, DIAPHRAGM CAM	Z85919 760615	4	4	4	4	4	4	4	4	4	4
3512849	161	PIN, EE SIGNAL	Z75817 760520				1						
3512850	162	SPRING, EE SIGNAL PIN	Z75940 760520				1						
3512857	90	SPRING, DETENT, 1.5	Z75920 760520	1	1	1	3	1	1	1	1	1	1
3512864	185	SCREW, DETENT	Z75950 760520				1						
3512866	183	SPRING, LEAF, DETENT	Z75726 760520				1						
3512872	204	SCREW, PIVOT, DIAPHRAGM LEVER	Z75951 760520					1					
3512885	209	SPRING, COIL, TENSION, 2.5x27.0	Z75957 760520					1					
3512891	215	SCREW, MOUNT STOP	Z75961 760520					1					
3512894	48	WASHER	Z75958 760520	1	1	1	1	1	1	1	1	1	1
3512898	89	BALL, STEEL, 1.6	Z75919 760520	1	1	1	3	60	1	1	1	1	1
3512899	98	BALL, STEEL, 1.2	Z75941 760520	1			120						
3512909	184	SCREW, AUTO DIAPHRAGM RING	Z75967 760520				1						
3512923	252	SPRING, ACTUATING RING	W25939 760817						1				
3512924	245	ARM, AUTO DIAPHRAGM COUPLING	Z75740 760520						1				
3512929	249	SCREW, MANUAL BUTTON	Z75974 760520						1				
3512931	255	PLATE, MOUNT LOCKING	Z75741 760520						1				
3512934	251	SCREW, STOP	Z75975 760520						1				
3512939	121	SCREW, PANHD, 1.7x3.0	Z38918 B761025	5									
3512971	139	SCREW, PANHD, 1.7x2.5	W25923 W760817		5						5	5	
3512974	21	SCREW, FLTHD, 1.4x2.5x2.0	Z75912 B760520	8	5	8	12	10	10	8	5	5	
3512976	28	SETSCREW, 1.4x1.5	Z75905 B760520	1	1	1	1	1	1	1	1	1	1
3512979	207	SCREW, COUNTERSUNK, 1.7x2.5	Z38927 W761025							4			
3512980	213	SCREW, PANHD, 1.7x3.0x3.0	Z75913 B760520							2			
3512982	52	SCREW, PANHD, 1.7x2.5	Z75933 B760520	8	8	8	8	8	8	8	8	8	8
3512984	182	SCREW, PANHD, 1.4x2.5x2.0	Z75922 B760520				2			2	2		
3512985	2	SCREW, FLTHD, 1.7x2.5	Z75927 B760520	5	5	5	5	5	5	5	5	5	5
3512986	200	SCREW, PANHD, 1.4x2.0	Z75926 B760520							2	2		
3512987	229	SCREW, FLTHD, 1.4x2.0	Z75968 W760520								3		
3512988	84	SETSCREW, 1.4x2.5	W25903 B760817	3	3	3	3	3	3	3	3	3	3
3512989	87	SCREW, PANHD, 1.7x2.5	Z75947 B760520	4	4	4	9	4	4	4	4	4	4
3512990	94	SCREW, PANHD, 1.4x2.5x2.0	Z75952 B760520	2	2	2	4	2	2	2	2	2	2
3513462	214	RING, BALL RTNG	Z38556 761025							1			
3513548	212	ARM, AUTO DIAPHRAGM COUPLING	Z38727 761025							1			
3513549	210	SHAFT, CAM OPERATING	Z38929 761025							1			
3513664	12	RING, HOOD	Z38505 761025	1	1	1	1	1	1	1	1	1	1
3513665	13	RING, INNER FOCUSING	Z38506 761025	1	1	1	1	1	1	1	1	1	1
3513666	14	SETSCREW, 1.4x1.7	Z38901 B761025	6	6	6	6	6	6	6	6	6	6
3513667	16	SCREW, CAM ROLLER SHAFT	Z38903 761025	2	2	2	2	2	2	2	2	2	2
3513668	15	ROLLER, CAM, CONTROL RING	Z38902 761025	2	2	2	2	2	2	2	2	2	2
3513669	20	RING B, ZOOM COLLAR	Z38508 761025	1	1	1	1	1	1	1	1	1	1
3513670	19	GRIP	Z38507 761025	1	1	1	1	1	1	1	1	1	1
3513671	23	RING A, ZOOM COLLAR	Z38509 761025	1	1	1	1	1	1	1	1	1	1
3513672	24	RING, SEAL	Z38904 761025	1	1	1	1	1	1	1	1	1	1
3513673	25	RING, BRIDGE	Z38510 761025	1	1	1	1	1	1	1	1	1	1
3513674	27	SCREW, BRIDGE ROLLER SHAFT	Z38906 761025	2	2	2	2	2	2	2	2	2	2
3513675	26	ROLLER, CAM, BRIDGE RING	Z38905 761025	2	2	2	2	2	2	2	2	2	2
3513676	29	HOUSING, 1ST LENS GROUP SLIDE	Z38511 761025	1	1	1	1	1	1	1	1	1	1
3513677	31	SCREW, SLIDE, TAPERED	Z38908 761025	2	2	2	2	2	2	2	2	2	2
3513678	30	WASHER	Z38907 761025	2	2	2	2	2	2	2	2	2	2
3513679	37	HOUSING, 2ND LENS GROUP SLIDE	Z38514 761025	1	1	1	1	1	1	1	1	1	1
3513680	39	SCREW, CAM ROLLER SHAFT	Z38909 761025	2	2	2	2	2	2	2	2	2	2
3513681	38	ROLLER, CAM SLOT, 2ND LENS GROUP	Z15903 760830	2	2	2	2	2	2	2	2	2	2
3513682	44	HOUSING, 3RD LENS GROUP SLIDE	Z38517 761025	1	1	1	1	1	1	1	1	1	1
3513683	46	SCREW, CAM ROLLER SHAFT	Z38911 761025	2	2	2	2	2	2	2	2	2	2
3513684	45	ROLLER, CAM, 3RD LENS GROUP	Z38910 761025	2	2	2	2	2	2	2	2	2	2

U N F M C K O P N/AI

35-85mm f/2.8 Varifocal
Series 1 Lens

Complete Parts List, continued

Vivitar Part No.	Ref.	Description	Part Code	Quantity								
				U	N/F	M	C	K	O	P	N/AI	
3513685	47	HELICOID, INNER	Z38518 761025	1	1	1	1	1	1	1	1	1
3513686	50	HELICOID, MIDDLE	Z38519 761025	1	1	1	1	1	1	1	1	1
3513687	53	HELICOID, OUTER	Z38520 761025	1	1	1	1	1	1	1	1	1
3513688	196	SPRING, EE PIN	Z38925 761025					1				
3513689	54	GUIDE, HELICOID	Z38701 761025	2	2	2	2	2	2	2	2	2
3513690	51	PLATE, INFINITY STOP	Z38700 761025	1	1	1	1	1	1	1	1	1
3513691-1	85	RING, INDEX, UNIV	Z38531UB761025	1								
3513691-2	124	RING, INDEX, N/F	Z38531NB761025		1							
3513691-3	142	RING, INDEX, MINOLTA	Z38531MB771215			1						
3513691-4	159	RING, INDEX, CANON	Z38531CB761025				1					
3513691-5	218	RING, INDEX, O/OM	Z38531OB761025						1			
3513691-6	193	RING, INDEX, K/AR	Z38531KB761025					1				
3513691-7	274	RING, INDEX, P/K	Z38531PB770228							1		
3513691-8	291	RING, INDEX, N/AI	Z38531FB770520								1	
3513692	31	SCREW, SLIDE, STRAIGHT	Z38908 761025	2	2	2	2	2	2	2	2	2
3513693	55	RING, ADJUSTMENT RTNR	Z38521 761025	1	1	1	1	1	1	1	1	1
3513694	56	RING, ECCENTRIC	Z38522 761025	1	1	1	1	1	1	1	1	1
3513695	60	HOUSING, DIAPHRAGM, FRONT	Z38525 761025	1	1	1	1	1	1	1	1	1
3513697	64	RING, DIAPHRAGM BLADE	Z38704 761025	1	1	1	1	1	1	1	1	1
3513698	65	RING, DIAPHRAGM BLADE ACTUATOR	Z38705 761025	1	1	1	1	1	1	1	1	1
3513699	505	DIAPHRAGM HOUSING ASSY, N/F, AI	Z38N95 N761025		1							1
3513700	66	RING, BLADE ACTUATOR BASE	Z38526 761025	1	1	1	1	1	1	1	1	1
3513701	68	SPRING, DIAPHRAGM	W25901 760817	1			1	1				
3513702	70	HOUSING, DIAPHRAGM, REAR	Z38527 761025	1	1	1	1	1	1	1	1	1
3513703	73	PLATE, DIAPHRAGM LIMIT STOP	Z38707 761025	1	1	1	1	1	1	1	1	1
3513704	72	ARM, DIAPHRAGM ACTUATOR	Z38706 761025	1	1	1	1	1	1	1	1	1
3513706	86	FRAME, MOUNT, UNIV	Z38566 761025	1								
3513707	88	PLATE, CAM RETAINER	Z38708 761025	3	3	3	3			3	3	
3513708	91	RING, APERTURE SETTING, UNIV	Z38532UB761025	1								
3513709	92	RING, APERTURE CAM	Z38735 761025	1								
3513710	95	RING, AUTO/MANUAL SELECT	Z38533 761025	1								
3513711	97	SCREW, STOP	Z38916 761025	1								
3513712	96	BUTTON, AUTO/MANUAL SELECT	Z38534 761025	1								
3513713	99	SPRING, DETENT, 1.2	Z75964 760520	1								
3513714	3	SETSCREW, 1.7x2.0	Z75902 B760520	2	1	1	1	1	1	1	1	1
3513716	100	RETAINER, APERTURE RING	Z38535 761025	1								
3513717-1	101	SHIM, FOCUS, 0.1, UNIV	Z38917 761025	A/R								
3513717-2	101	SHIM, FOCUS, 0.15, UNIV	Z38944 761025	A/R								
3513717-3	101	SHIM, FOCUS, 0.2, UNIV	Z38945 761025	A/R								
3513718	518	LEVER, AUTO DIAPHRAGM	Z38U75 N761025	1								
3512719	103	SPRING, DIAPHRAGM LEVER	W25906 760817	1								
3513720	112	ARM, AUTO DIAPHRAGM ACTUATOR	Z38712 761025	1	1	1	1				1	
3513724	120	MOUNT, UNIVERSAL	Z38536 761025	1								
3513725	116	SCREW, PANHD, 1.4x2.5, BLK	Z85910 B760615	2								
3513726	519	CRANK, AUTO DIAPHRAGM TRANSFER	Z38U74 N761025	1								
3513727	123	PIPE, SHADE	Z38537 761025	1								
3513728	125	FRAME, MOUNT, N/F	Z38538 761025		1							
3513729	126	RING, APERTURE SETTING	Z38539NB761025		1							
3513730	129	RING, APERTURE CAM	Z38713 761025		1						1	
3513731	522	LEVER, AUTO DIAPHRAGM	Z38N75 N761025		1							
3513732	140	PIPE, SHADE, NIKON	Z38540 761025		1							1
3513733	143	RING, APERTURE SETTING	Z38541MB770514			1						
3513734	144	FRAME, MOUNT, MINOLTA	Z38542 761025			1						
3513735	146	RING, APERTURE CAM	Z38715 761025			1						
3513736	525	LEVER, AUTO DIAPHRAGM, M & MD	Z38M75 N761025			1						
3513737	147	SCREW, PIVOT, DIAPHRAGM LEVER	Z38803 761025			1						
3513738	148	SPRING, DIAPHRAGM ACTUATOR LEVER	Z38919 761025			1						
3513739	153	SCREW, PANHD, 1.4x2.5	Z38920 B761025			2						
3513740	155	SPACER, GUIDE PLATE	Z38921 761025			2						
3513741	156	MOUNT, MINOLTA	Z38543 770514			1						

U N/F M C K O P N/AI

Complete Parts List, continued

Vivitar Part No.	Ref.	Description	Part Code	Quantity										
				U	N	M	C	K	O	P	N/AI			
3513742	157	SCREW, PANHD, 1.7x3.0, CHR	Z38922 W761025			4		4						
3513743	158	PIPE, SHADE	Z38544 761025			1								
3513744	160	RING, DIAPHRAGM SETTING	Z38545CB761025					1						
3513745	163	FRAME, MOUNT, CANON	Z38546 761025					1						
3513746	164	RING, APERTURE CAM	Z38717 761025					1						
3513747	165	PLATE, LATCH	Z38718 761025					1						
3513748-1	166	SHIM, FOCUS, 0.1, CANON	Z38923 761025					A/R						
3513748-2	166	SHIM, FOCUS, 0.15, CANON	Z38946 761025					A/R						
3513748-3	166	SHIM, FOCUS, 0.2, CANON	Z38947 761025					A/R						
3513749	167	RING, BALL RTNR	W25539 760817					1						
3513751	168	SCREW, DIAPHRAGM COUPLING	Z38924 761025					1						
3513752	169	CAM, APERTURE	Z38719 761025					1						
3513753	170	RING, APERTURE SIGNAL	Z38547 761025					1						
3513754	171	RETAINER, SIGNAL RING	Z38720 761025					1		1				
3513755	172	SCREW, PIVOT, DIAPHRAGM LEVER	W25916 760817					1						
3513756	527	LEVER, AUTO DIAPHRAGM	Z38C75 N761025					1						
3513757	178	SCREW, STOP PLATE	W25922 760817					4						
3513758	177	SPRING, COIL, TENSION	Z38940 761025					1						
3513759	179	PLATE, STOP	W25721 760817					2						
3513760	180	MOUNT, CANON	Z38548 761025					1						
3513761	186	RING, AUTO DIAPHRAGM	Z38549 761025					1						
3513762	187	RING, BALL RTNG	W25543 760817					1						
3513764	191	LUG, BREECHLOCK SIGNAL	W25722 760817					1						
3513765	192	RING, BREECHLOCK	Z38551 761025					1						
3513766	219	RING, APERTURE SETTING	Z38558OB761025									1		
3513767	220	FRAME, MOUNT, O/OM	Z38559 761025									1		
3513768	221	PLATE, CAM RTNR	Z38728 761025									3		
3513769	222	SCREW, FLTHD, 1.7x2.5	Z38931 8761025									3	2	
3513770	223	RING, APERTURE CAM	Z38729 761025					1				1		
3513771-1	224	SHIM, COUPLING ARM, 0.1	Z38937 761025									A/R		
3513771-2	224	SHIM, COUPLING ARM, 0.15	Z38950 761025									A/R		
3513771-3	224	SHIM, COUPLING ARM, 0.5	Z38951 761025									A/R		
3513772	225	ARM, APERTURE SIGNAL COUPLING	Z38730 761025									1		
3513773	227	RING, RTNG, APERTURE CAM	Z38560 761025									1		
3513774-1	228	SHIM, FOCUS, 0.1, O/OM	Z70923 761030									A/R		
3513774-2	228	SHIM, FOCUS, 0.15, O/OM	Z70933 761030									A/R		
3513774-3	228	SHIM, FOCUS, 0.2, OM	Z70934 761030									A/R		
3513775	230	RING, LOCK BUTTON RTNG	Z75735 760520									1		
3513776	234	ARM, AUTO DIAPHRAGM ACTUATOR	Z38732 761025									1		
3513777	232	SCREW, PIVOT, AUTO LEVER	Z38933 761025									1		
3513778	533	LEVER, AUTO DIAPHRAGM	Z38075 N761025									1		
3513779	236	SCREW, PIVOT, MANUAL LEVER	Z38934 761025									1		
3513780	237	SPRING, MANUAL LEVER	Z38935 761025									1		
3513781	534	LEVER, MANUAL	Z38073 N761025									1		
3513783	240	SPRING, LEAF, LOCK RELEASE	Z75737 760520									1		
3513784	241	PLATE, GUIDE	W25732 760817									1		
3513785	242	PLATE, DIAPHRAGM STOP	Z38734 761025									1		
3513786	247	SCREW, CAM ROLLER	W25933 760817									1		
3513787	248	ROLLER, CAM, MANUAL	W25934 760817									1		
3513788	244	RING, AUTO DIAPHRAGM	W25558 760817									1		
3513792	254	SCREW, LOCK PLATE	W25936 760817									1		
3513798	258	PIPE, SHADE	Z38561 761025									1		
3513799	1	FRAME, FILTER	Z38500 761025	1	1	1	1	1	1	1	1	1	1	1
3513800	4	RING, NAME	Z38501 761025	1	1	1	1	1	1	1	1	1	1	1
3513801	5	LENS ELEMENT, 1ST	G00081 761025	1	1	1	1	1	1	1	1	1	1	1
3513802	6	RING, SPACER, 1ST & 2ND ELEMENT	Z38502 761025	1	1	1	1	1	1	1	1	1	1	1
3513803	7	LENS ELEMENT, 2ND	G00082 761025	1	1	1	1	1	1	1	1	1	1	1
3513804	8	HOUSING, 1ST LENS GROUP	Z38503 761025	1	1	1	1	1	1	1	1	1	1	1
3513805	9	LENS ELEMENT, 3RD	G00083 761025	1	1	1	1	1	1	1	1	1	1	1
3513806	10	RING, RTNG, 1ST LENS GROUP	Z38504 761025	1	1	1	1	1	1	1	1	1	1	1

U N F M C K O P N/AI

35-85mm f/2.8 Varifocal
Series 1 Lens

Complete Parts List, continued

Vivitar Part No.	Ref.	Description	Part Code	Quantity								
				U	N/F	M	C	K	O	P	N/AI	
3513807-1	11	SHIM, FOCUS, FRONT, 0.1	Z38900 761025	----- As Required -----								
3513807-2	11	SHIM, FOCUS, FRONT, 0.15	Z38941 761025	----- As Required -----								
3513807-3	11	SHIM, FOCUS, FRONT, 0.2	Z38942 761025	----- As Required -----								
3513808	32	HOUSING, 2ND LENS GROUP	Z38512 761025	1	1	1	1	1	1	1	1	1
3513809	502	LENS DOUBLET, 4TH & 5TH ELEMENTS	Z38U99 N761025	1	1	1	1	1	1	1	1	1
3513810	35	RING, RTNG, 2ND LENS GROUP	Z38513 761025	1	1	1	1	1	1	1	1	1
3513811	40	RING, RTNG, 3RD LENS GROUP	Z38515 761025	1	1	1	1	1	1	1	1	1
3513812	503	LENS DOUBLET, 6TH & 7TH ELEMENTS	Z38U98 N761025	1	1	1	1	1	1	1	1	1
3513813	43	CELL, 3RD LENS GROUP	Z38516 761025	1	1	1	1	1	1	1	1	1
3513814	57	RING, RTNG, 8TH ELEMENT	Z38523 761025	1	1	1	1	1	1	1	1	1
3513815	58	LENS ELEMENT, 8TH	G00088 761025	1	1	1	1	1	1	1	1	1
3513816	59	HOUSING, 4TH LENS GROUP	Z38524 761025	1	1	1	1	1	1	1	1	1
3513817	75	RING, 9TH & 10TH LENS RTNG	Z38528 761025	1	1	1	1	1	1	1	1	1
3513818	510	LENS DOUBLET, 9TH & 10TH ELEMENTS	Z38U94 N761025	1	1	1	1	1	1	1	1	1
3513819-1	78	SHIM, FOCUS, 0.1, REAR LENS GROUP	Z38915 761025	----- As Required -----								
3513819-2	78	SHIM, FOCUS, 0.2, REAR LENS GROUP	Z38943 761025	----- As Required -----								
3513820	79	HOUSING, REAR LENS GROUP	Z38529 761025	1	1	1	1	1	1	1	1	1
3513821	80	LENS ELEMENT, 11TH	G00091 761025	1	1	1	1	1	1	1	1	1
3513822	81	RING, SPACER, 11TH & 12TH ELEMENTS	Z38530 761025	1	1	1	1	1	1	1	1	1
3513823	82	LENS ELEMENT, 12TH	G00092 761025	1	1	1	1	1	1	1	1	1
3513824	83	RING, RTNG, 12TH ELEMENT	Z38565 761025	1	1	1	1	1	1	1	1	1
3513826	253	MOUNT, OLYMPUS	W25559 760817							1		
3513827	504	DIAPHRAGM HOUSING ASSY, UNIV	Z38U95 N761025	1								
3513828	509	DIAPHRAGM HOUSING ASSY, OLYMPUS	Z38O95 N761025							1		
3513829	511	LENS GROUP ASSY, 1ST	Z38U90 N761025	1	1	1	1	1	1	1	1	1
3513830	515	LENS GROUP ASSY, 5TH	Z38U85 N761025	1	1	1	1	1	1	1	1	1
3513831	536	MOUNT ASSY, COMPLETE, UNIV	Z38U65 N761025	1								
3513832	537	MOUNT ASSY, COMPLETE, N/F	Z38N65 N761025		1							
3513833	538	MOUNT ASSY, COMPLETE, MINOLTA	Z38M65 N761025			1						
3513834	539	MOUNT ASSY, COMPLETE, CANON	Z38C65 N761025				1					
3513835	541	MOUNT ASSY, COMPLETE, O/OM	Z38O65 N761025							1		
3513836-1	506	DIAPHRAGM HOUSING ASSY, MINOLTA	Z38M95 N761025			1						
3513836-2	507	DIAPHRAGM HOUSING ASSY, CANON	Z38C95 N761025				1					
3513836-3	508	DIAPHRAGM HOUSING ASSY, KONICA	Z38K95 N761025					1				
3513837	176	SPRING, COIL, TENSION	Z38938 761025				1					
3513845	131	SPRING, AUTO DIAPHRAGM LEVER	Z75931 760520		1							1
3513859	63	SCREW, FLTHD, 1.4x2.5	Z75963 B760520	12	7	7	6	5	8	7	7	
3513901	289	SCREW, FLTHD, 1.4x2.0, CHR	Z75963 W760520							3		
3513950	216	MOUNT, KONICA	W25552 760817					1				
3514043	194	FRAME, INTERMEDIATE, K/AR	Z38552 761025					1				
3514045	195	PLATE, CAM RTNR	Z38722 761025					3				
3514047	197	SCREW, PIVOT, EE SIGNAL LEVER	Z38926 761025					1				
3514048	199	RING, APERTURE CAM	Z38724 761025					1				
3514089	141	SCREW, FLTHD, 1.4x2.0, CHR	Z75912 W760520		2							2
3514121	217	PIPE, SHADE	Z38557 761025					1				
3514279	530	LEVER, EE SIGNAL	Z38K71 N761025					1				
3514280	203	RING, APERTURE SETTING	Z38553K B761025					1				
3514281	202	BUTTON, EE LATCH RELEASE	Z38807 761025					1				
3514282	201	SPRING, EE LATCH RELEASE	Z38725 761025					1				
3514285	205	LEVER, AUTO DIAPHRAGM	Z38726 761025					1				
3514286	206	FRAME, MOUNT, K/AR	Z38554 761025					1				
3514287-1	208	SHIM, FOCUS, REAR, 0.1, KONICA	Z38928 761025					A/R				
3514287-2	208	SHIM, FOCUS, REAR, 0.15, KONICA	Z38948 761025					A/R				
3514287-4	208	SHIM, FOCUS, REAR, 0.2, KONICA	Z38949 761025					A/R				
3514301	540	MOUNT ASSY, COMPLETE, KONICA	Z38K65 N761025					1				
3514302	516	HELICOID ASSY	Z38U80 N761025	1	1	1	1	1	1	1	1	1
3518091	257	SCREW, PANHD, 1.7x5.0x2.9	Z75985 W760520						4			
3518095	278	SHIM, APERTURE ARM	Z70941 770228								1	
3518096	279	ARM, APERTURE COUPLING	Z75744 770228								1	
3518098-1	286	SHIM, FOCUS, 0.2, P/K	Z70924 770228								A/R	

U N/F M C K O P N/AI

35-85mm f/2.8 Varifocal
Series 1 Lens

Complete Parts List, continued

Vivitar Part No.	Ref.	Description	Part Code	Quantity									
				U	N/A	M	C	K	O	P	N/A		
3518098-2	286	SHIM, FOCUS, 0.15, P/K	Z70935 770228									A/R	
3518098-3	286	SHIM, FOCUS, 0.1, P/K	Z70936 770228									A/R	
3518100	281	SCREW, PIVOT, AUTO LEVER	K90916 770606									1	
3518101	287	PLATE, GUIDE, AUTO LEVER	Z75743 770228									1	
3518102	288	MOUNT, P/K	Z70548 770228									1	
3518107	294	FORK, METER COUPLING	Z75747 770520										1
3518108	295	SCREW, METER COUPLING FORK	Z15917 770520										1
3518109	297	SHIM, FOCUS, 0.5, N/AI	Z70937 770520										A/R
3518110-1	298	SHIM, FOCUS, 0.2, N/AI	Z70938 770520										A/R
3518110-2	298	SHIM, FOCUS, 0.15, N/AI	Z70939 770520										A/R
3518110-3	298	SHIM, FOCUS, 0.1, N/AI	Z70940 770520										A/R
3518112	299	MOUNT, N/AI	Z75588 770520										1
3518131	282	SPRING, WIRE, AUTO LEVER	K90917 770606									1	

U N/A M C K O P N/AI



Prepared by:
Technical Publications Department

Vivitar Corporation
Corporate Offices:
1630 Stewart Street, Santa Monica, Ca 90406

Printed in U.S.A.

Vivitar is an International Trademark of Vivitar Corporation.